

TYPE: A5CH2

PISTON CHECK - CLASS 800 - FORGED STEEL ASTM A105N

THREADED END NPT OR SOCKET WELD

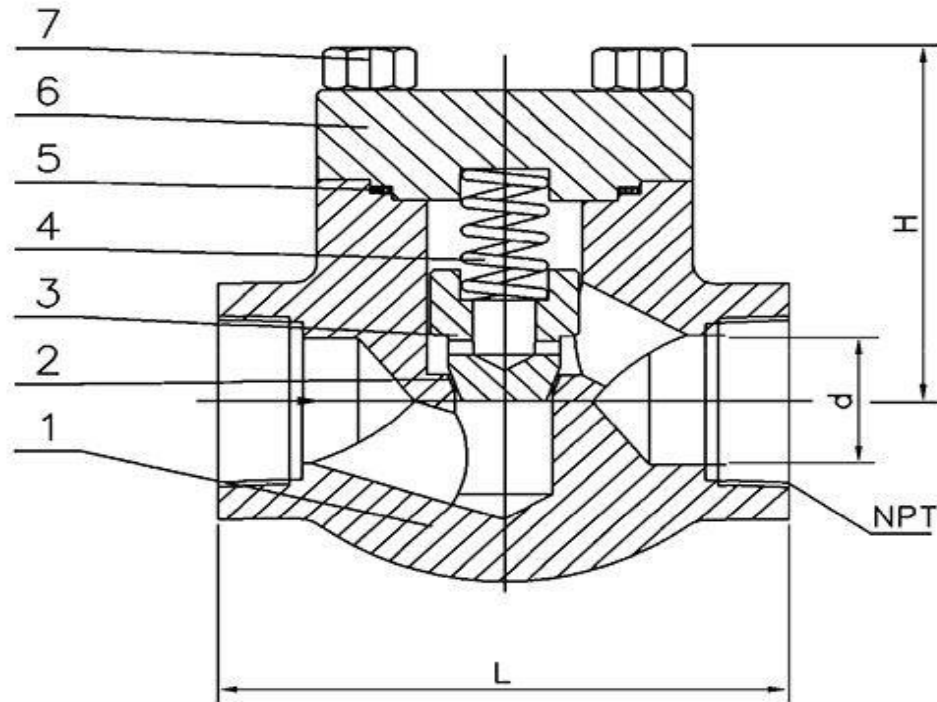

NO.	PART NAME	MATERIAL
1	Body	ASTM A105N
2	Seat	Integral Hardface Stellite
3	Disc	ASTM A276 420
4	Spring	SS304
5	Gasket	Graphite + SS304
6	Bonnet	ASTM A105N
7	Bolt	ASTM A193 B7

DIMENSIONS:

NPT	DN	d	L	H											
1/2	15	10	79	61											
3/4	20	13	92	65											
1	25	18	111	79											
1-1/4	32	23	120	95											
1-1/2	40	30	152	103											
2	50	35	172	118											

MANUFACTURE STANDARD	Valve Design	API 602 BS5352
	Test and Inspection	API 598
	Threaded End	ASME B1.20.1
	Socket End	ASME B16.11
	Pressure rating	Class 800

Drawing No.	Date	Type	Rev. No.	By
A51005	2016.05.30	A5CH2	02	AT

THREADED END NPT OR SOCKET WELD