



aerospace
climate control
electromechanical
filtration
fluid & gas handling
hydraulics
pneumatics
process control
sealing & shielding



High Flow Valve Actuation Range
NAMUR Valves G1/4" & G1/2"
Piped Valves G1/4" & G1/2"
Banjo Valves G1/8" & G1/4"
for Control of Pneumatic Actuators



ENGINEERING YOUR SUCCESS.

Market Description

Process industries
 Chemical, Petrochemical industries
 Oil & Gas
 Water & Sewage
 Pulp & Paper
 Food & Beverage
 Pharmaceutical industry
 Powder Dosing-Transportation
 Air Dryers

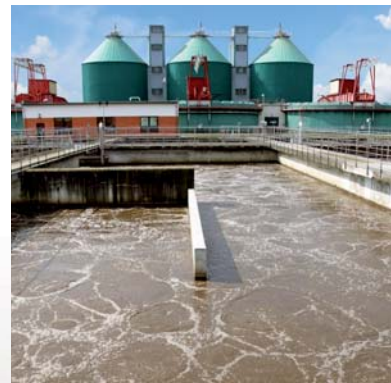

Description of Applications

Control of single or double acting pneumatic actuators, in safe or dangerous areas.

NAMUR Interfaces 1/4" & 1/2"

The interface design is conform to the NAMUR standard and to the VDI/VDE 3845 recommendations of the actuator industry. It allows a compact design of the actuator/valve unit. In case of a 3/2 function, the air of the actuator spring chamber also flows through the pilot valve (re-breather function). This prevents corrosion of the actuator springs.

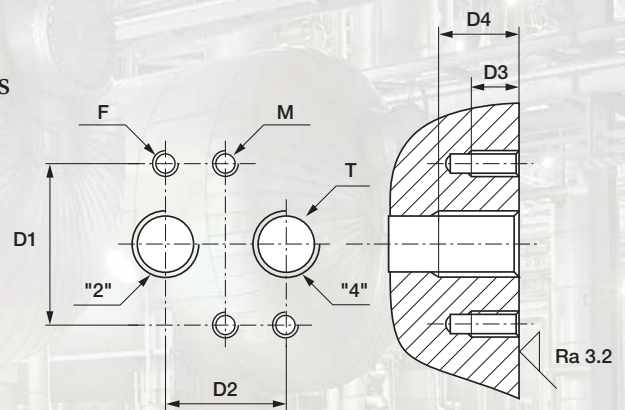

F	T	D1 mm	D2 mm	D3 mm	D4 min. mm	M
M5	1/4	32	24	8	12	M5
M6	1/2	45	40	10	16	M6

F: 2 mounting holes - T: 2 actuators control port - M: 2 holes for dowel pins

Customer Value Proposition

- High flow: 1.250 l/min (1/4"), 3.000 l/min (1/2")
- Compact design
- Long life expectancy
- N3x & P3x Series compatible with any Parker Lucifer coil (ATEX or not) of electrical group 2 (8/9 W coils)
- Fail safe standard
- Reduced inventory (3/2 & 5/2 functions with the same valve on 341Nx5 series)
- Mechanical part of the valve ATEX certified according standard EN 13463-1 & -5



General Information

Function:	3/2, 5/2, 3/2 <=> 5/2 and 5/3 valves.
Manual override:	Standard on all versions.
Design:	Nxx & Pxx Series: Solenoid operated spool valve with combined spring and air return & external air pressure operated versions. B0x Series: Solenoid direct acting valve with spring return.
Mounting:	Nxx Series: For direct mounting on NAMUR interface 1/4" & 1/2" Pxx Series: Piped valves G1/4" & G1/2" Bxx Series: Equipped with a banjo bolt G1/8" or G1/4"
Mounting position:	Indifferent.
Material specifications:	Aluminium body. Internal parts of stainless steel. Sealing material from NBR.
Range of admissible pressure drop:	Δp min. = see table. Δp max. = 10 bar.
Media:	Dry or lubricated air.
Fluid temperature:	Min. 0°C Max. + 50°C
Ambient temperature:	-10°C to +50°C
Electrical part:	N0x / P0x / Bxx Series are compatible with 22 mm coil 496131 / 496482 / 496637 series N3x / P3x Series are compatible with 32/37/40 mm coils part of electrical group 2 (8/9W), including 481865 / 495870 / 495905 Series.
Solenoid duty:	100% ED.
Voltage:	481865 coil: 12 VDC , 24 VDC , 48 VDC , 110VDC, 24 V / 50 AC, 48 V / 50 AC, 110 V / 50 AC, 220-230V/50 AC, 115 V / 60 Hz AC, 230 V / 60 AC.
Voltage tolerance:	± 10% of nominal for 481865 coil.
Class of insulation material:	Class F for 481865 coil.
Standards:	Mechanical ATEX conform to EN 13463-1 & -5.

NAMUR Valves G1/4" Series

Solenoid Operated Versions N03-N05 Series with 22 mm Coil

Port size	Orifice	Q _n	Admissible differential pressure (bar)		Max. admissible fluid temperature (°C)	Seat disc	Reference number			Consumption Power (Watt)		Weight (g)	Dimensions Reference	
			max.	min.			DC=	AC~	Valve	Housing	Coil			DC
G	mm	l/min	min	DC=	AC~	Air & Neutral gases		Valve	Housing	Coil	DC	AC		

3/2 Solenoid operated - Combined spring & air return (monostable)

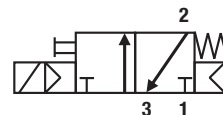

1/4	7	1250	2.5	10	10	50	NBR	331N03	-	496131	3	3	300	1
1/4	7	1250	2.5	10	10	50	NBR	331N03	-	496482	3	3	300	1
1/4	7	1250	2.5	10	10	50	NBR	331N03	-	496637	3	3	300	1

5/2 Solenoid operated - Combined spring & air return (monostable)

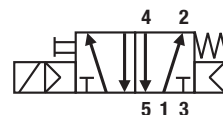

1/4	7	1250	2.5	10	10	50	NBR	341N03	-	496131	3	3	300	2
1/4	7	1250	2.5	10	10	50	NBR	341N03	-	496482	3	3	300	2
1/4	7	1250	2.5	10	10	50	NBR	341N03	-	496637	3	3	300	2

3/2 <=> 5/2 with conversion plate - Solenoid operated Combined spring & air return (monostable)

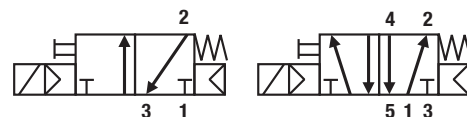

1/4	7	1250	2.5	10	10	50	NBR	341N05	-	496131	3	3	310	3
1/4	7	1250	2.5	10	10	50	NBR	341N05	-	496482	3	3	310	3
1/4	7	1250	2.5	10	10	50	NBR	341N05	-	496637	3	3	310	3

5/2 Solenoid operated and return (bistable)

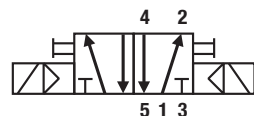

1/4	7	1250	2.5	10	10	50	NBR	347N03	-	496131	3	3	430	4
1/4	7	1250	2.5	10	10	50	NBR	347N03	-	496482	3	3	430	4
1/4	7	1250	2.5	10	10	50	NBR	347N03	-	496637	3	3	430	4

5/3 W1 closed in center position - Solenoid operated and return

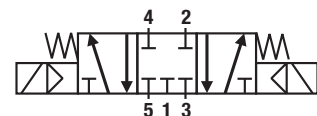

1/4	7	1250	2.5	10	10	50	NBR	342N03	-	496131	3	3	430	4
1/4	7	1250	2.5	10	10	50	NBR	342N03	-	496482	3	3	430	4
1/4	7	1250	2.5	10	10	50	NBR	342N03	-	496637	3	3	430	4

5/3 W3 exhausted in center position Solenoid operated and return

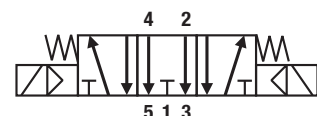

1/4	7	1250	2.5	10	10	50	NBR	343N03	-	496131	3	3	430	4
1/4	7	1250	2.5	10	10	50	NBR	343N03	-	496482	3	3	430	4
1/4	7	1250	2.5	10	10	50	NBR	343N03	-	496637	3	3	430	4

Please consult the "How to Order" part at the end of each coil chapter.

Dimensions Reference 1

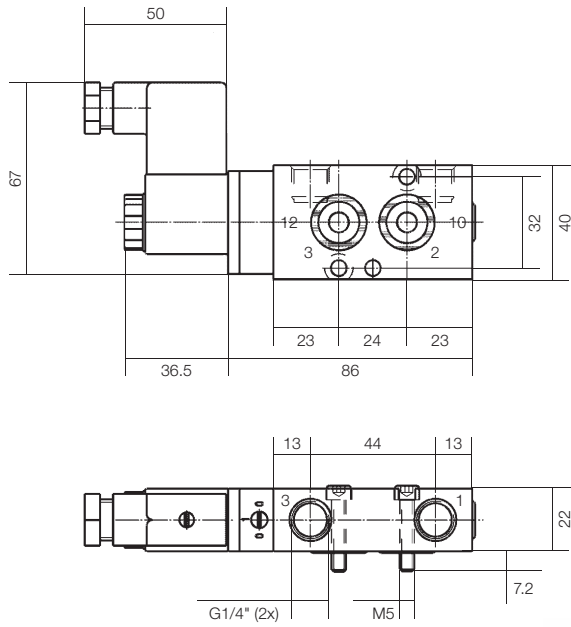

Dimensions Reference 2

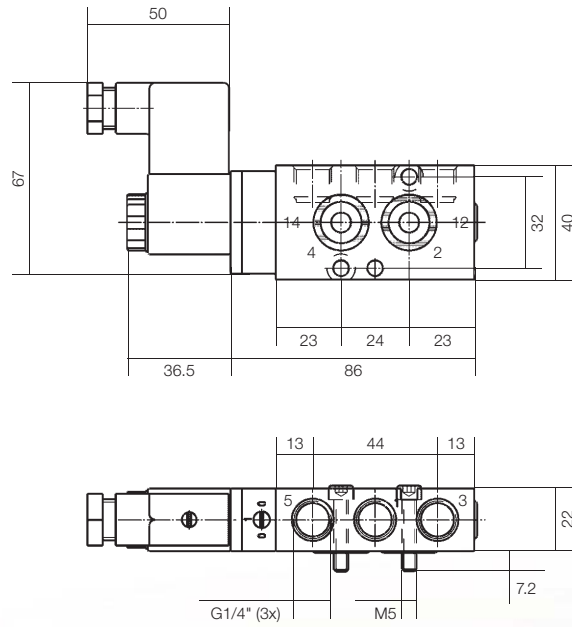

Dimensions Reference 3

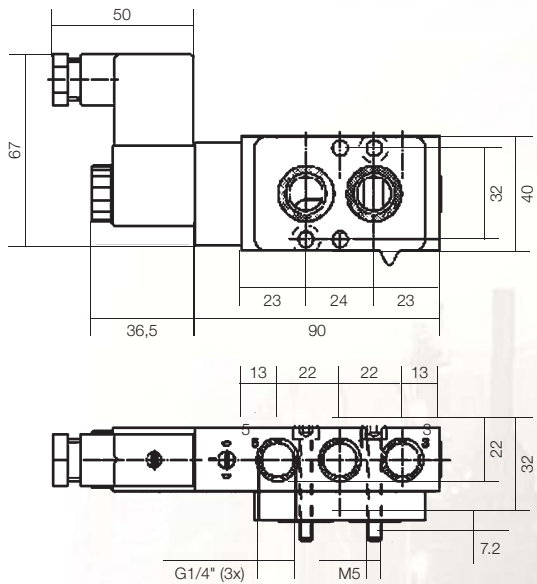

Dimensions Reference 4

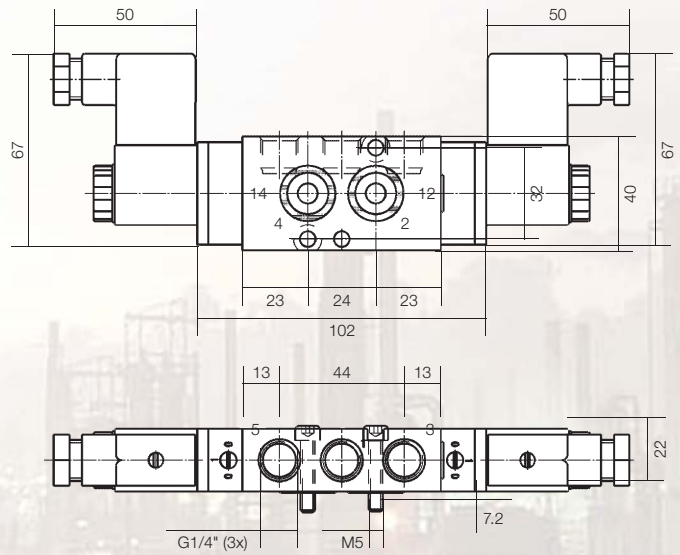

NAMUR Valves G1/4" Series

Solenoid Operated Versions

N33-N35 Series with 32 / 37 / 40 mm Coil

Port size	Orifice	Q _N	Admissible differential pressure (bar)		Max. admissible fluid temperature (°C)	Seat disc	Reference number			Consumption Power (Watt)		Weight (g)	Elect. Group	Dim. Ref.
			max.	min.			DC=	AC~	Valve	Housing	Coil			
G	mm	l/min	min	DC=	AC~	Air & Neutral gases								

3/2 <=> 5/2 with conversion plate - Solenoid operated Combined spring & air return (monostable)

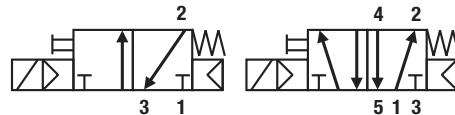

1/4	7	1250	2.5	10	10	50	NBR	341N35	2995	481865	9	8	480	2	5
1/4	7	1250	2.5	10	10	50	NBR	341N35	2995	495870	9	8	700	2	-
1/4	7	1250	2.5	10	10	50	NBR	341N35	-	495905	8	8	740	2	-

5/2 Solenoid operated and return (bistable)

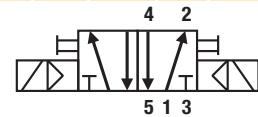

1/4	7	1250	2.5	10	10	50	NBR	347N33	2995	481865	9	8	750	2	6
1/4	7	1250	2.5	10	10	50	NBR	347N33	2995	495870	9	8	1190	2	-
1/4	7	1250	2.5	10	10	50	NBR	347N33	-	495905	8	8	1270	2	-

5/3 W1 Closed in center position Solenoid operated and return

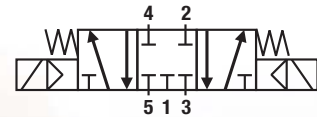

1/4	7	1250	2.5	10	10	50	NBR	342N33	2995	481865	9	8	750	2	6
1/4	7	1250	2.5	10	10	50	NBR	342N33	2995	495870	9	8	1190	2	-
1/4	7	1250	2.5	10	10	50	NBR	342N33	-	495905	8	8	1270	2	-

Dimensions Reference 5

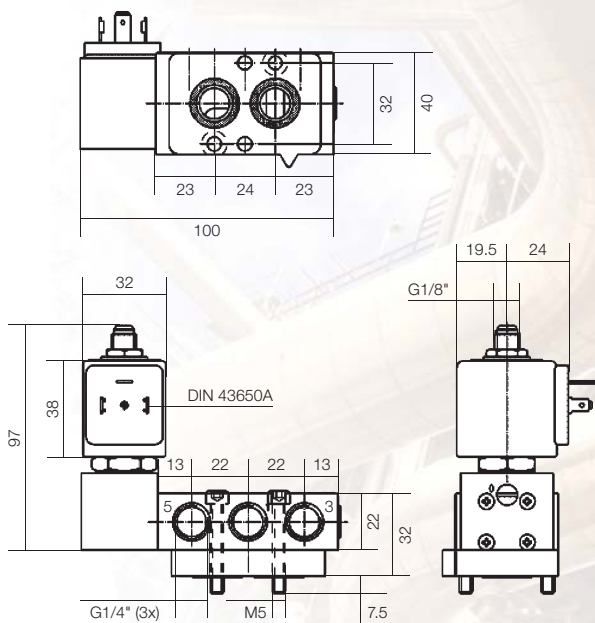

Dimensions Reference 6

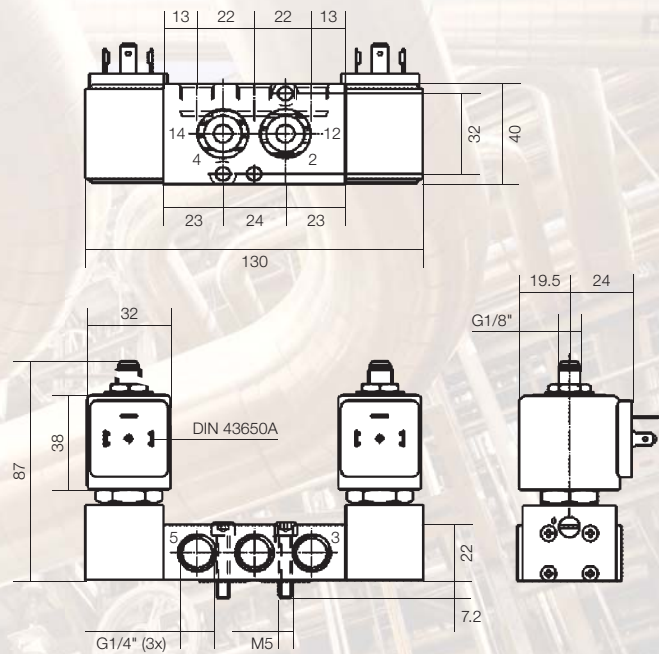

Please consult the "How to Order" part at the end of each coil chapter.

NAMUR Valves G1/4" Series

External Pressure Air Operated Series 5xx N03 Series

Port size	Orifice	Q _N	Admissible differential pressure (bar)		Max. admissible fluid temperature (°C)	Seat disc	Reference number			Consumption Power (Watt)		Weight (g)	Dimensions Reference
			max.	min.			Valve	Housing	Coil	DC	AC		
G	mm	l/min	min	DC=	AC~	Air & Neutral gases							

3/2 External pressure air operated
Combined spring & air return (monostable)
External pressure supply 2.5 to 10 bar

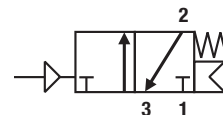

1/4	7	1250	2.5	10	10	50	NBR	531N03	-	w/o	-	-	210	7
-----	---	------	-----	----	----	----	-----	--------	---	-----	---	---	-----	---

5/2 External pressure air operated
Combined spring & air return (monostable)
External pressure supply 2.5 to 10 bar

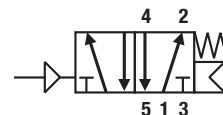

1/4	7	1250	2.5	10	10	50	NBR	541N03	-	w/o	-	-	210	8
-----	---	------	-----	----	----	----	-----	--------	---	-----	---	---	-----	---

5/2 External pressure air operated
External pressure air return (bistable)
External pressure supply 2.5 to 10 bar

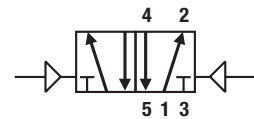

1/4	7	1250	2.5	10	10	50	NBR	547N03	-	w/o	-	-	240	9
-----	---	------	-----	----	----	----	-----	--------	---	-----	---	---	-----	---

5/3 W1 closed in center position - External pressure air operated
External pressure air return
External pressure supply 2.5 to 10 bar

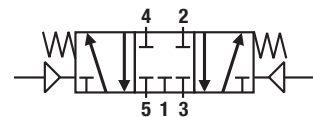

1/4	7	1250	2.5	10	10	50	NBR	542N03	-	w/o	-	-	240	9
-----	---	------	-----	----	----	----	-----	--------	---	-----	---	---	-----	---

Dimensions Reference 7

Dimensions Reference 8

Dimensions Reference 9

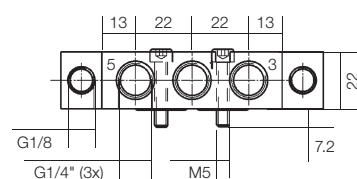
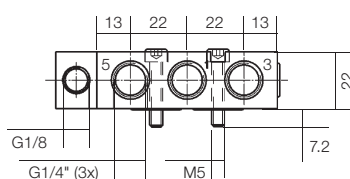
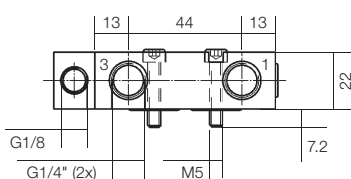
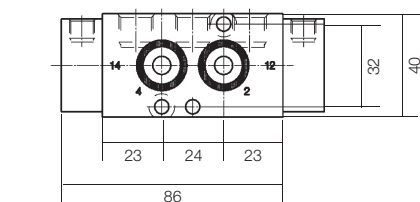
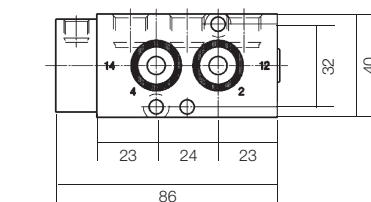
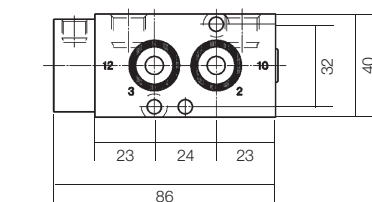

NAMUR Valves G1/2" Series

Solenoid Operated Versions N04 Versions with 22 mm Coil

Port size	Orifice	Q _N	Admissible differential pressure (bar)		Max. admissible fluid temperature (°C)	Seat disc	Reference number			Consumption Power (Watt)		Weight (g)	Dimensions Reference	
			max.	min.			DC=	AC~	Valve	Housing	Coil			DC
G	mm	l/min	min	DC=	AC~	Air & Neutral gases		Valve	Housing	Coil	DC	AC		

3/2 Solenoid operated Combined spring & air return (monostable)

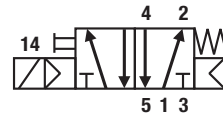

1/2	12	3000	2.5	10	10	50	NBR	331N04	-	496131	3	3	910	670	10
1/2	12	3000	2.5	10	10	50	NBR	331N04	-	496482	3	3	1130	670	10
1/2	12	3000	2.5	10	10	50	NBR	331N04	-	496637	3	3	1170	670	10

5/2 Solenoid operated Combined spring & air return (monostable)

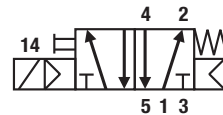

1/2	12	3000	2.5	10	10	50	NBR	341N04	-	496131	3	3	900	840	11
1/2	12	3000	2.5	10	10	50	NBR	341N04	-	496482	3	3	1120	840	11
1/2	12	3000	2.5	10	10	50	NBR	341N04	-	496637	3	3	1160	840	11

5/2 Solenoid operated and return (bistable)



1/2	12	3000	2.5	10	10	50	NBR	347N04	-	496131	3	3	1240	840	12
1/2	12	3000	2.5	10	10	50	NBR	347N04	-	496482	3	3	1680	840	12
1/2	12	3000	2.5	10	10	50	NBR	347N04	-	496637	3	3	1760	840	12

Dimensions Reference 10

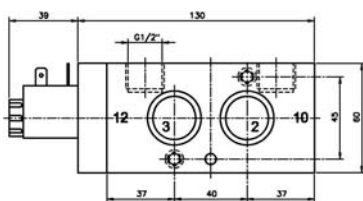

Dimensions Reference 11

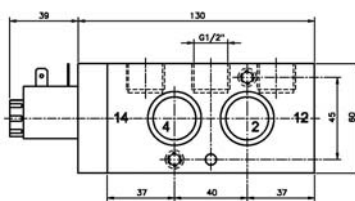

Dimensions Reference 12

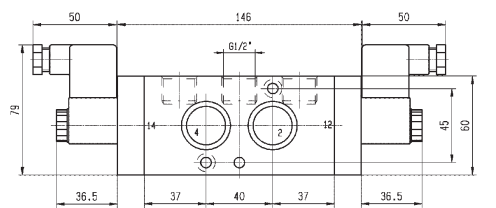

Please consult the "How to Order" part at the end of each coil chapter.

NAMUR Valves G1/2" Series

Solenoid Operated Versions N34 Series with 32 / 37 / 40 mm Coil

Port size	Orifice	Q _N	Admissible differential pressure (bar)		Max. admissible fluid temperature (°C)	Seat disc	Reference number			Consumption Power (Watt)		Weight (g)	Elect. Group	Dim. Ref.
			max.	AC~			Valve	Housing	Coil	DC	AC			
G	mm	l/min	min	DC=	AC~	Air & Neutral gases								

3/2 Solenoid operated Combined spring & air return (monostable)

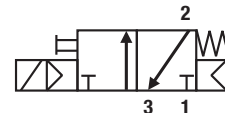

1/2	12	3000	2.5	10	10	50	NBR	331N34	2995	481865	9	8	910	2	13
1/2	12	3000	2.5	10	10	50	NBR	331N34	2995	495870	9	8	1130	2	-
1/2	12	3000	2.5	10	10	50	NBR	331N34	-	495905	8	8	1170	2	-

5/2 Solenoid operated Combined spring & air return (monostable)

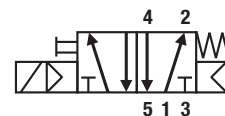

1/2	12	3000	2.5	10	10	50	NBR	341N34	2995	481865	9	8	900	2	14
1/2	12	3000	2.5	10	10	50	NBR	341N34	2995	495870	9	8	1120	2	-
1/2	12	3000	2.5	10	10	50	NBR	341N34	-	495905	8	8	1160	2	-

5/2 Solenoid operated and return (bistable)

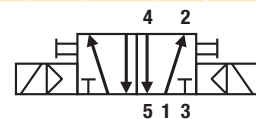

1/2	12	3000	2.5	10	10	50	NBR	347N34	2995	481865	9	8	1240	2	15
1/2	12	3000	2.5	10	10	50	NBR	347N34	2995	495870	9	8	1680	2	-
1/2	12	3000	2.5	10	10	50	NBR	347N34	-	495905	8	8	1760	2	-

Dimensions Reference 13

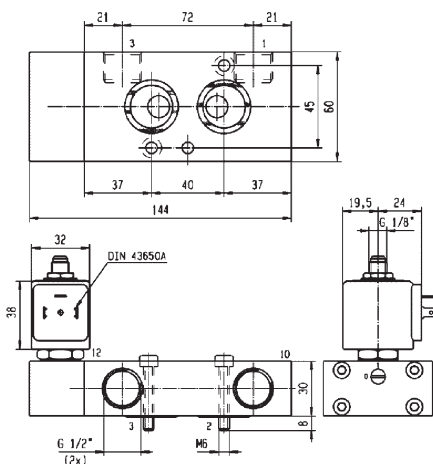

Dimensions Reference 14

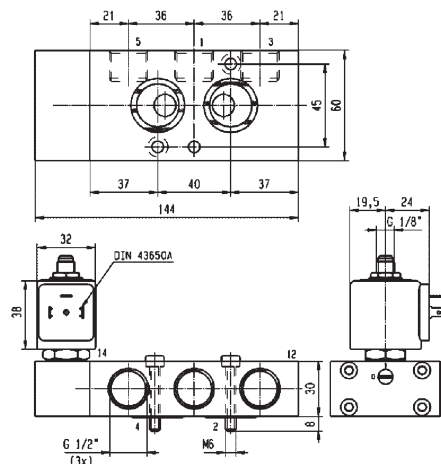

Dimensions Reference 15

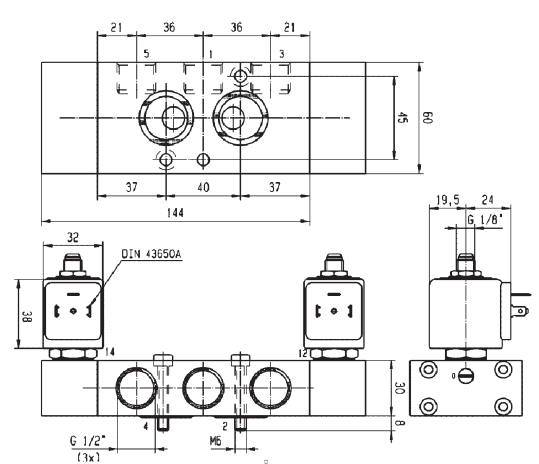

Please consult the "How to Order" part at the end of each coil chapter.

NAMUR Valves G1/2" Series

External Pressure Air Operated Series 5 xx N04 Series

Port size	Orifice	Q _N	Admissible differential pressure (bar)		Max. admissible fluid temperature (°C)	Seat disc	Reference number			Consumption Power (Watt)		Weight (g)	Dimensions Reference
			max.	min.			Valve	Housing	Coil	DC	AC		
G	mm	l/min	min	DC= AC~	Air & Neutral gases		Valve	Housing	Coil	DC	AC		

3/2 External pressure air operated
Combined spring & air return (monostable)
External pressure supply 2.5 to 10 bar

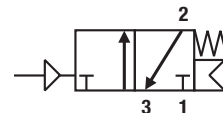

1/2	12	3000	2.5	10	10	50	NBR	531N04	-	w/o	-	-	620	16
-----	----	------	-----	----	----	----	-----	---------------	---	-----	---	---	-----	----

5/2 External pressure air operated
Combined spring & air return (monostable)
External pressure supply 2.5 to 10 bar

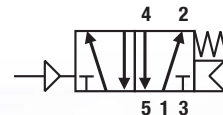

1/2	12	3000	2.5	10	10	50	NBR	541N04	-	w/o	-	-	600	17
-----	----	------	-----	----	----	----	-----	---------------	---	-----	---	---	-----	----

Dimensions Reference 16

Dimensions Reference 17

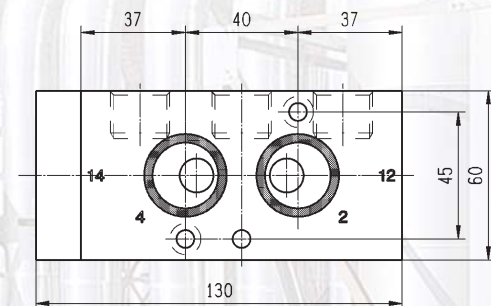
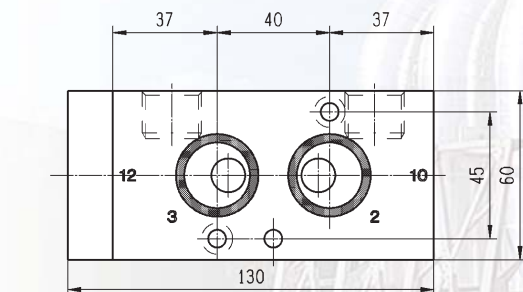

Please consult the "How to Order" part at the end of each coil chapter.

Piped Valves - G1/4" Series

Solenoid Operated Versions P03 Versions with 22 mm Coil

Port size	Orifice	Q _N	Admissible differential pressure (bar)		Max. admissible fluid temperature (°C)	Seat disc	Reference number			Consumption Power (Watt)		Weight (g)	Dimensions Reference	
			max.	min.			DC=	AC~	Valve	Housing	Coil			DC
G	mm	l/min	min	DC=	AC~	Air & Neutral gases		Valve	Housing	Coil	DC	AC		

5/2 Solenoid operated Combined spring & air return (monostable)

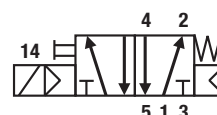

1/4	7	1250	2.5	10	10	50	NBR	341P03	-	496131	3	3	250	18
1/4	7	1250	2.5	10	10	50	NBR	341P03	-	496482	3	3	250	18
1/4	7	1250	2.5	10	10	50	NBR	341P03	-	496637	3	3	250	18

5/2 Solenoid operated and return (bistable)



1/4	7	1250	2.5	10	10	50	NBR	347P03	-	496131	3	3	350	19
1/4	7	1250	2.5	10	10	50	NBR	347P03	-	496482	3	3	350	19
1/4	7	1250	2.5	10	10	50	NBR	347P03	-	496637	3	3	350	19

Dimensions Reference 18

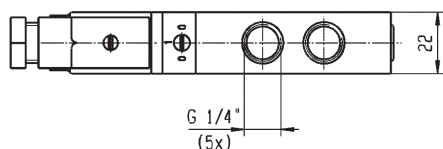
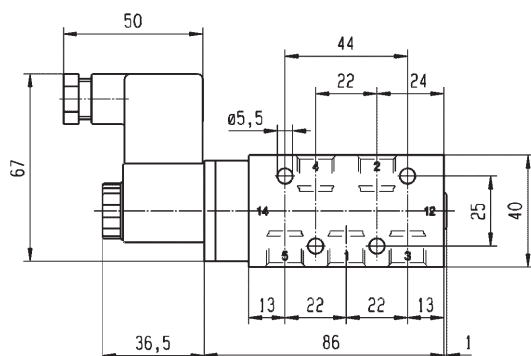

Dimensions Reference 19

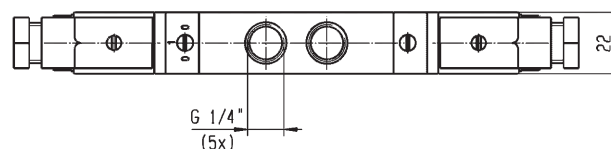
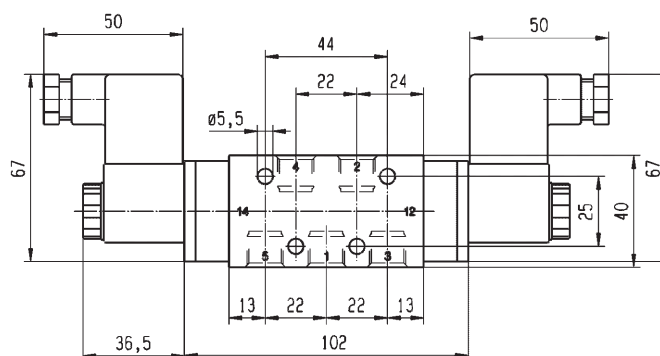

Please consult the "How to Order" part at the end of each coil chapter.

Piped Valves - G1/4" Series

Solenoid Operated Versions

P33 Versions with 32-37-40 mm Coil

Port size	Orifice	Q _v	Admissible differential pressure (bar)		Max. admissible fluid temperature (°C)	Seat disc	Reference number			Consumption Power (Watt)		Weight (g)	Elect. Group	Dim. Ref.
			max.	min.			DC=	AC~	Valve	Housing	Coil			
G	mm	l/min	min	DC=	AC~	Air & Neutral gases								

5/2 Solenoid operated Combined spring & air return (monostable)

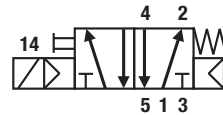

1/4	7	1250	2.5	10	10	50	NBR	341P33	2995	481865	9	8	470	2	20
1/4	7	1250	2.5	10	10	50	NBR	341P33	2995	495870	9	8	690	2	-
1/4	7	1250	2.5	10	10	50	NBR	341P33	-	495905	8	8	730	2	-

5/2 Solenoid operated and return (bistable)

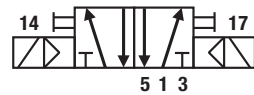

1/4	7	1250	2.5	10	10	50	NBR	347P33	2995	481865	9	8	750	2	21
1/4	7	1250	2.5	10	10	50	NBR	347P33	2995	495870	9	8	1190	2	-
1/4	7	1250	2.5	10	10	50	NBR	347P33	-	495905	8	8	1270	2	-

Dimensions Reference 20

Dimensions Reference 21

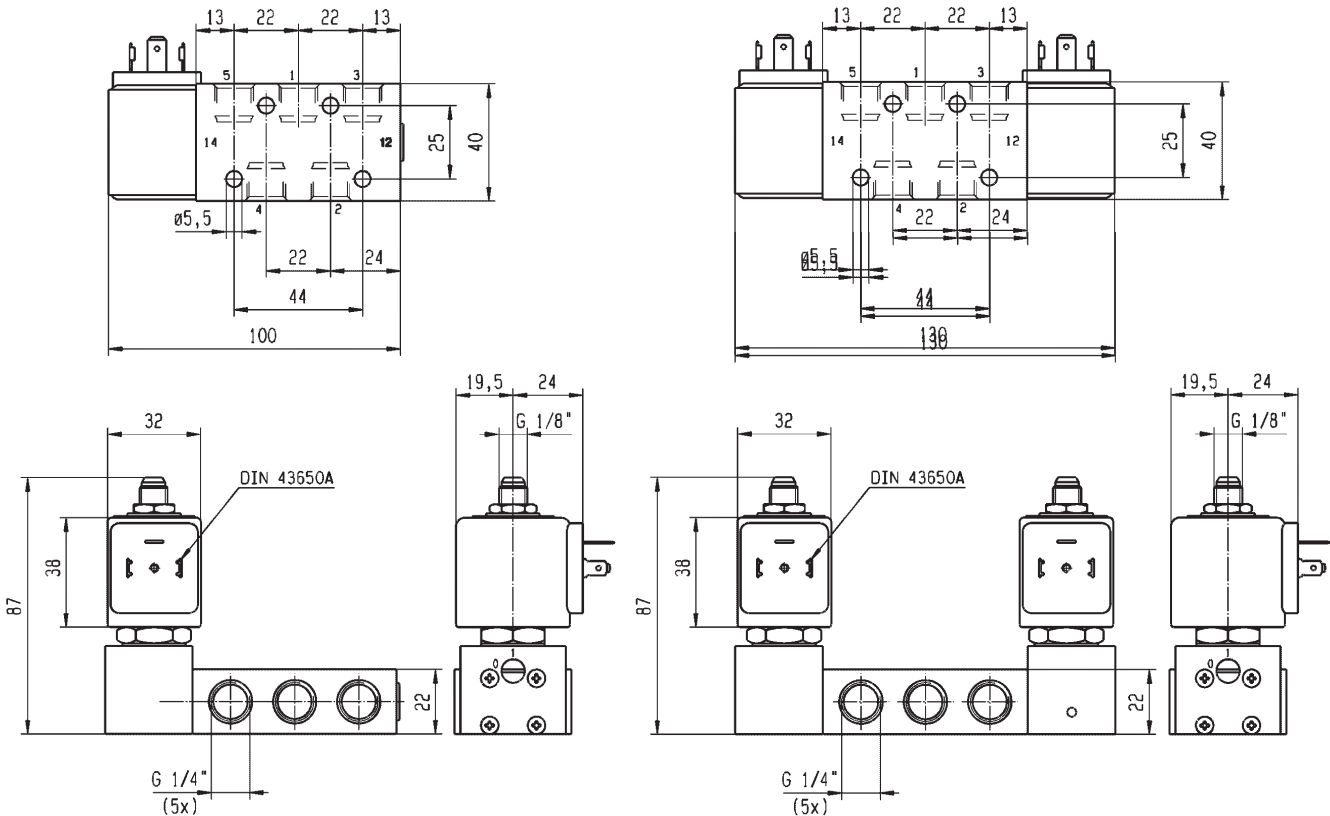

Please consult the "How to Order" part at the end of each coil chapter.

Piped Valves - G1/2" Series

Solenoid Operated Versions
P04 Versions with 22 mm Coil

Port size	Orifice	Q _N	Admissible differential pressure (bar)		Max. admissible fluid temperature (°C)	Seat disc	Reference number			Consumption Power (Watt)		Weight (g)	Dimensions Reference
			max.	min.			DC=	AC~	Valve	Housing	Coil		
G	mm	l/min	min	DC=	AC~	Air & Neutral gases							

5/2 Solenoid operated Combined spring & air return (monostable)

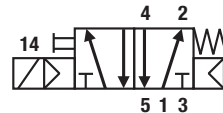

1/2	12	3000	2.5	10	10	50	NBR	341P04	-	496131	3	3	670	22
1/2	12	3000	2.5	10	10	50	NBR	341P04	-	496482	3	3	670	22
1/2	12	3000	2.5	10	10	50	NBR	341P04	-	496637	3	3	670	22

5/2 Solenoid operated and return (bistable)

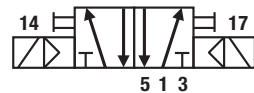

1/2	12	3000	2.5	10	10	50	NBR	347P04	-	496131	3	3	840	23
1/2	12	3000	2.5	10	10	50	NBR	347P04	-	496482	3	3	840	23
1/2	12	3000	2.5	10	10	50	NBR	347P04	-	496637	3	3	840	23

Dimensions Reference 22

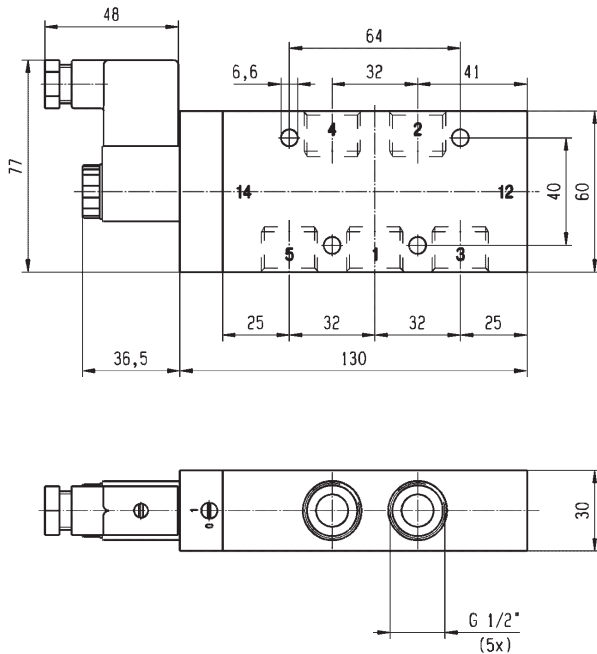

Dimensions Reference 23

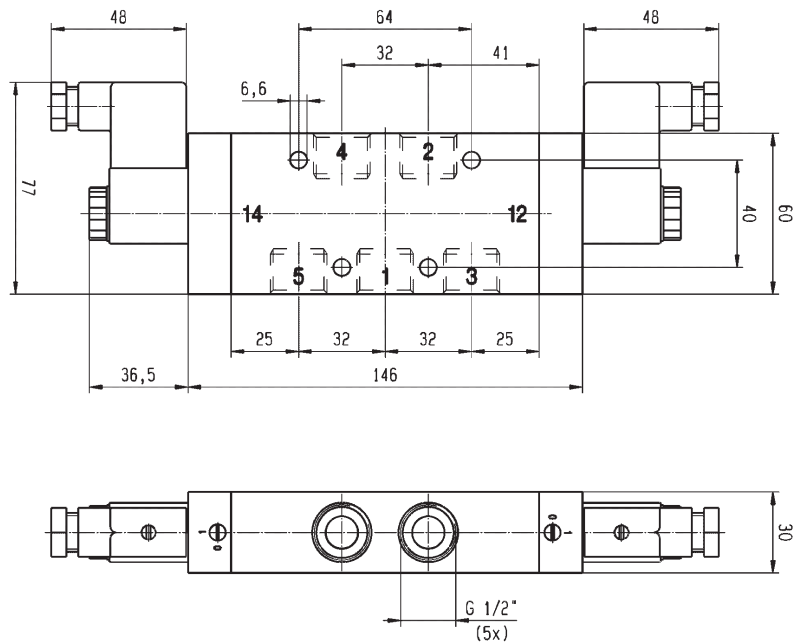

Please consult the "How to Order" part at the end of each coil chapter.

Piped Valves - G1/2" Series

Solenoid Operated Versions

P34 Versions with 32/37/40 mm Coil

Port size	Orifice	Q _v	Admissible differential pressure (bar)		Max. admissible fluid temperature (°C)	Seat disc	Reference number			Consumption Power (Watt)		Weight (g)	Elect. Group	Dim. Ref.
			max.	min.			DC=	AC~	Valve	Housing	Coil			
G	mm	l/min	min	DC=	AC~	Air & Neutral gases		Valve	Housing	Coil	DC	AC		

5/2 Solenoid operated Combined spring & air return (monostable)

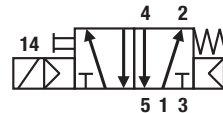

1/2	12	3000	2.5	10	10	50	NBR	341P34	2995	481865	9	8	900	2	24
1/2	12	3000	2.5	10	10	50	NBR	341P34	2995	495870	9	8	1120	2	-
1/2	12	3000	2.5	10	10	50	NBR	341P34	-	495905	8	8	1160	2	-

5/2 Solenoid operated and return (bistable)

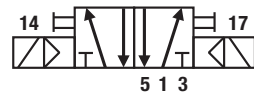

1/2	12	3000	2.5	10	10	50	NBR	347P34	2995	481865	9	8	1240	2	25
1/2	12	3000	2.5	10	10	50	NBR	347P34	2995	495870	9	8	1680	2	-
1/2	12	3000	2.5	10	10	50	NBR	347P34	-	495905	8	8	1760	2	-

Dimensions Reference 24

Dimensions Reference 25

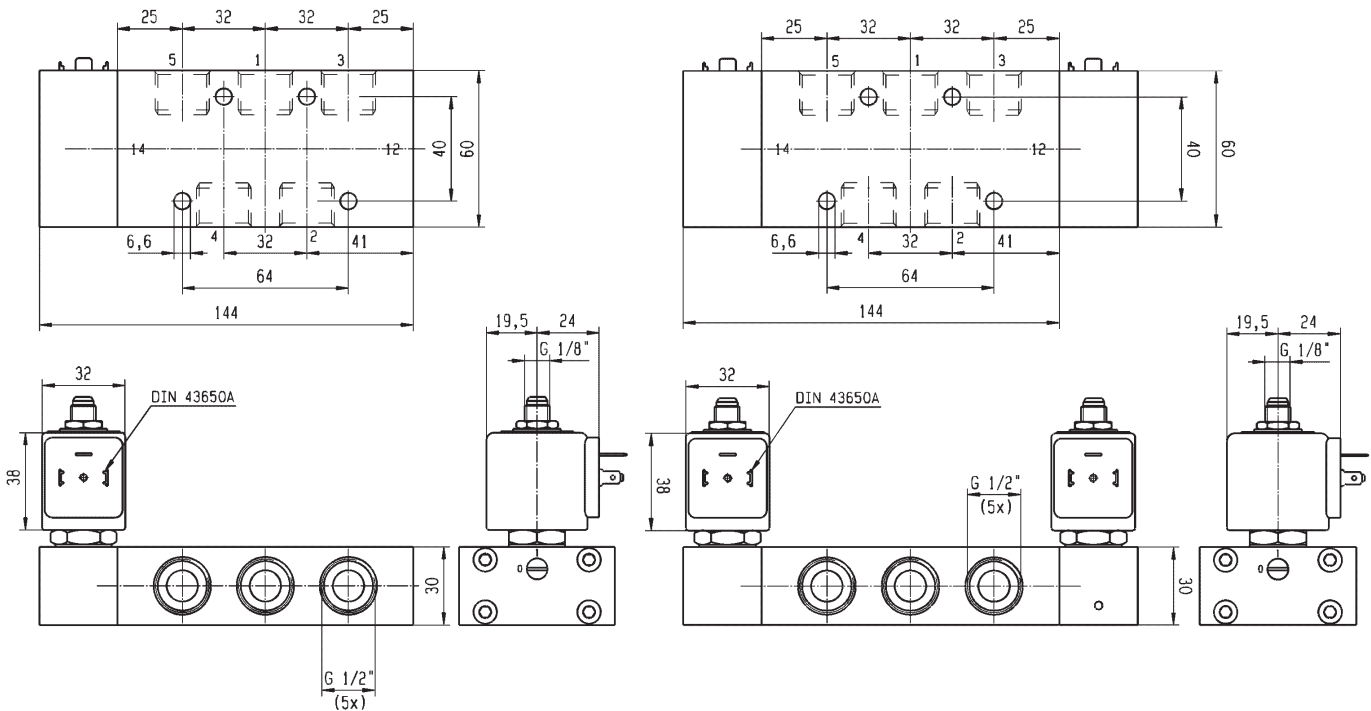

Please consult the "How to Order" part at the end of each coil chapter.

Banjo Valves - G1/4" & G1/8" Series

Solenoid Operated Versions

B03-B04 Versions with 22 mm Coil

Port size	Orifice	Q _N	Admissible differential pressure (bar)		Max. admissible fluid temperature (°C)	Seat disc	Reference number			Consumption Power (Watt)		Weight (g)	Dimensions Reference
			max.	min.			Valve	Housing	Coil	DC	AC		
G	mm	l/min	min	DC=	AC~	Air & Neutral gases							

3/2 Solenoid operated - Spring return (monostable)

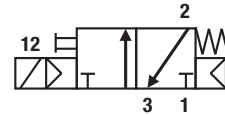

1/8	1.2	50	0	10	10	50	NBR	131B14	-	496131	3	3	140	26
1/8	1.2	50	0	10	10	50	NBR	131B14	-	496482	3	3	140	26
1/8	1.2	50	0	10	10	50	NBR	131B14	-	496637	3	3	140	26

3/2 Solenoid operated - Spring return (monostable)

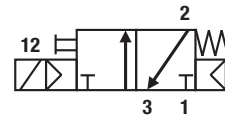

1/4	1.2	50	0	10	10	50	NBR	131B04	-	496131	3	3	160	27
1/4	1.2	50	0	10	10	50	NBR	131B04	-	496482	3	3	160	27
1/4	1.2	50	0	10	10	50	NBR	131B04	-	496637	3	3	160	27

Dimensions Reference 26

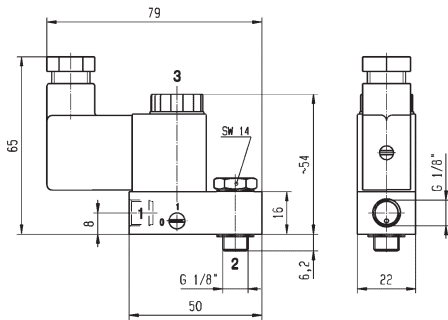

Dimensions Reference 27

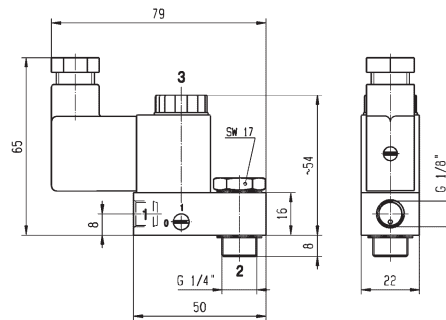

Please consult the "How to Order" part at the end of each coil chapter.

Coils and Spare Parts Informations

Coils 22 mm for N03-N05 Series Safe Area & ATEX Zone 22

Ref. 496131 / 496482 / 496637

These coils with connection for 2 P+G DIN 43650 B plug are encapsulated in synthetic material, conform to the IEC/CENELEC safety standards and comply with European low voltage directive 73/23/EC .

- Power: 3W
 - Insulation Class: F (155°C)
 - Degree of Protection: IP65 (with plug)
 - Duty Cycle: 100% ED
 - Ambient Temperature: -10°C to 50°C
- 3 different types are available:**
- **Ref. 496131** for a safe area without plug
 - **Ref. 496482** for a safe area with plug
 - **Ref. 496637** for an ATEX area Zone 22 

496637 coil series with connection 2P + G when mounted together with the supplied Pg9 plug (delivered with the coil) are suitable for use in dangerous areas (dust Zone 22) according to the European directive ATEX 94/9/C. Protection mode: Ex tD A22 IP65 - T95°C

Available Voltages	Safe area without DIN plug Order Code	Safe area with DIN plug Order Code	ATEX Zone 22 EX II 3D Order Code
12 VDC	496131 C1	496482 C1	496637 C1
24 VDC	496131 C2	496482 C2	496637 C2
48 VDC	496131 C4	496482 C4	496637 C4
110 VDC	496131 C5	496482 C5	496637 C5
24/50-60 VAC	496131 P0	496482 P0	496637 P0
48/50-60 VAC	496131 S4	496482 S4	496637 S4
110/50-60 VAC	496131 P2	496482 P2	496637 P2
115/60 VAC	496131 K8	496482 K8	496637 K8
230/50-60 VAC	496131 P9	496482 P9	496637 P9

How to Order

The housing kit is already included into the coil reference, so it's not needed to add it with the order code:

Valve Reference Number - Coil Reference - Voltage code = Order code

Example: 341N03 - 496131 C2

Valves and coils may be ordered also separately.

Coils 32 mm / 37 mm / 40 mm for N33-N34-N35 Series Safe Area

Ref. 481865

N3x series are compatible with any Parker Lucifer coil part of electrical group 2. That group includes many different coils for safe areas or areas submitted to ATEX certifications. These coils are part of the 8/9W class.

These coils with connection for 2P+G DIN 43650 A plug are encapsulated in synthetic material, conform to the IEC/CENELEC safety standards and comply with European low voltage directive 73/23/EC.

- Power: 8W (AC) 9W (DC)
- Insulation Class: F (155°C)
- Degree of Protection: IP65 (with plug)
- Duty Cycle: 100% ED
- Voltage Tolerance -10% / +10%
- Ambient Temperature -40°C / +50°C
 - ▶ The application can be limited also by the temperature range of the valve

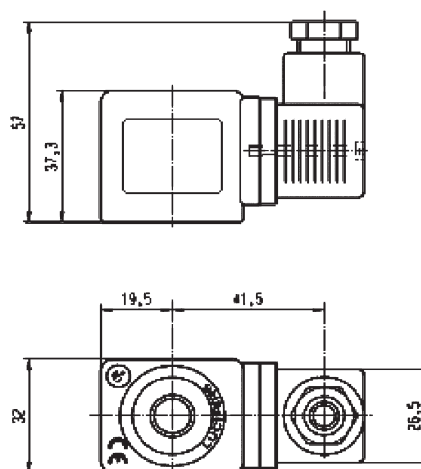

Available Voltages	Order Code
12 VDC	481865 C1
24 VDC	481865 C2
48 VDC	481865 C4
110 VDC	481865 C5
24/50 VAC	481865 A2
48/50 VAC	481865 A4
110/50 VAC	481865 A5
220-230/50 VAC	481865 3D
380/50 VAC	481865 A9
24/60 VAC	481865 B2
115/60 VAC	481865 K8
230/60 VAC	481865 J3



How to Order

This coil must be used together with a housing kit which includes a nut, a plate, and a washer. Housing Kit Order Code: **2995**

Valve Reference Number - Housing Reference - Coil Reference - Voltage Code = Order Code

Example: 341N35 - 2995 - 481865 C2

Valves and coils may be ordered also separately.

Coils and Spare Parts Informations

Coils 32 mm / 37 mm / 40 mm for N33-N34-N35 Series Safe Area Coil 481000 Series with 4538 Watertight and dust proof housing IP67

Ref. 481000

Coil 481000 series is encapsulated in synthetic material. Electrical connection is made with screw terminals for wire up to 1.5 mm. This coil conforms to the IEC/CENELEC safety standards and complies with European low voltage directive 73/23/EC. It must be used with a metallic housing.

- Power: 8W
- Insulation Class: F (155°C)
- Degree of Protection: IP67 (with 4538 housing)
- Duty Cycle: 100%
- Voltage Tolerance -10%/+10%
- Ambient Temperature -40°C/+50°C
- ▶ The application can be limited also by the temperature range of the valve

Available Voltages	Order Code
12 VDC	481000 C1
24 VDC	481000 C2
48 VDC	481000 C4
110 VDC	481000 C5
24/50 VAC	481000 A2
48/50 VAC	481000 A4
110-115/50 VAC	481000 OA
220-230/50 VAC	481000 3D
380/50-440/60 VAC	481000 5P
24/60 VAC	481000 B2
110-115/60 VAC	481000 6J
220-240/60 VAC	481000 4K
42/50-48/60 VAC	481000 S7

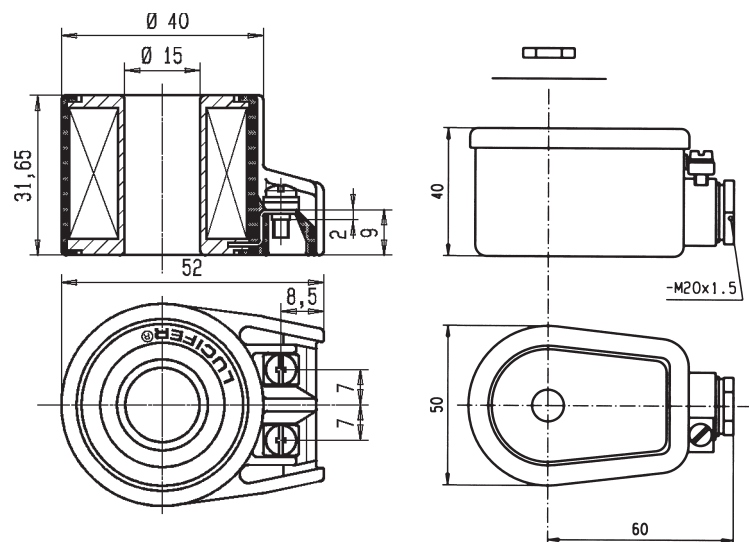

Housing 4538

This enclosure is dust and water proof. It corresponds to the protection degree IP67 according to IEC/EN60529. Corrosion resistant, the metallic housing offers good protection for the coil against shocks. It can be 360° orientable. This housing must be equipped with 481000 series coil.

Material: galvanized passivated steel - Degree of protection IP67 according to IEC/EN 60529 - Electrical connection: cable connection by cable gland according to DIN46320. Cable with outer diameter 6.5-13.5 mm (M20x1.5) can be simply sealed using a rubber gland resilient sealing rings. The enclosure is internally and externally fitted with grounding and earthing screw terminals.

How to Order

Valve Reference Number - Housing Reference - Coil Reference - Voltage Code = Order Code

Example: 331N34 - 4538 - 481000C2

Valves and coils may be ordered also separately.

Coils 32 mm / 37 mm / 40 mm for N33-N34-N35 Series ATEX Zone 2-22

Ref. 495870

This coil with connection 2P+G - when mounted together with the supplied Pg 9 plug (delivered with the coil), is suitable for use in Gas and Dust dangerous areas (**Zone 2-22**), according to the European directive **ATEX 94/9/C**.

Certificate LCIE 05 ATEX 6003 X - Protection mode: non sparking / limited energy solenoid

- II 3 G - Ex nAC IIC T3 / T4
- II 3 D - Ex tD A22 IP65 - T 195°C / T 130°C



- Power: 8W (AC) 9W (DC)
- Insulation Class: F (155°C)
- Degree of Protection: IP65 (with plug)
- Duty Cycle: 100% ED
- Voltage Tolerance -10%/+10%
- Ambient temperature
 - ▶ T3 (gaz) T 195°C (dust) -40°C/+65°C
 - ▶ T4 (gaz) T 130°C (dust) -40°C/+50°C
 - ▶ The application can be limited also by the temperature range of the valve

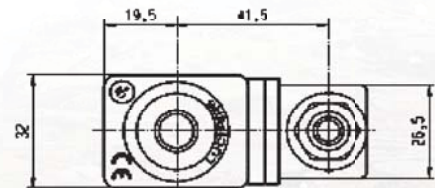
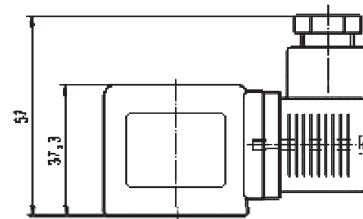

Available Voltages	Order Code
24 VDC	495870 C2
48 VDC	495870 C4
110 VDC	495870 C5
24/50 VAC	495870 A2
48/50 VAC	495870 A4
110/50 VAC	495870 A5
220-230/50 VAC	495870 3D



How to Order

This coil must be used together with a housing kit which includes a nut, a plate, and a washer. Housing kit order code: **2995**

Valve Reference Number - Coil Reference - Voltage code = Order code

Example: 331N34 - 2995 - 495870 A5

Valves and coils may be ordered also separately.

Coils 32 mm / 37 mm / 40 mm for N33-N34-N35 Series ATEX Zone 1-21

Ref. 495905

This coil is suitable for use in Gas and Dust dangerous areas (**Zone 1-21**), according to the European directive **ATEX 94/9/C**. It's also IECEx certified according to the IECEx Scheme. **Certificate LCIE 02 ATEX 6451 X - Protection modes: Explosionproof solenoids with flameproof enclosure / encapsulation "d mb"**

- II 2 G - Ex d mb IIC T4
- II 2 D - Ex tD A21 IP67 - T 130°C
- Insulation Class H (180°C)
- Power: 8W (AC-DC)
- Degree of Protection IP67
- Duty Cycle 100%
- Voltage Tolerance -10%/+10%
- Ambient Temperature: -40°C/+65°C
 - The application can be limited also by the temperature range of the valve

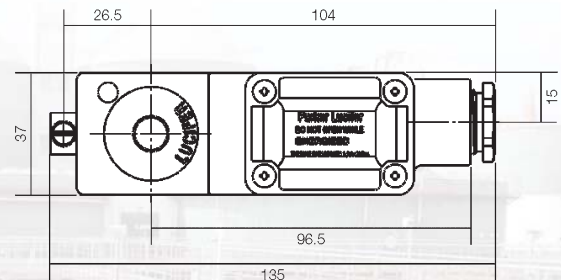
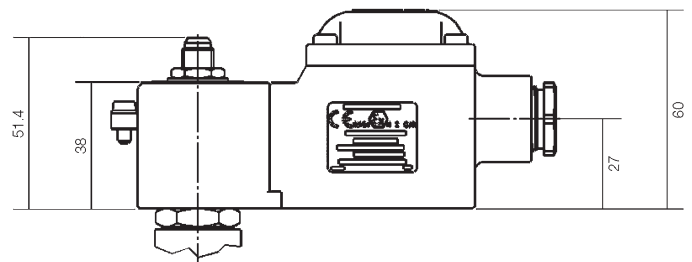

Available Voltages	Order Code
24 VDC	495905 C2
48 VDC	495905 C4
110 VDC	495905 C5
24/50 VAC	495905 A2
48/50 VAC	495905 A4
110/50 VAC	495905 E5
220-230/50 VAC	495905 3D
115/60	495905 E5
240/60	495905 B8

Electric connection is done in the connection box on an easily accessible connector terminals.
M20x1.5 Cable gland



How to Order

The housing kit is already included into the coil reference, so it's not needed to add it in the order code:
Valve Reference Number - Coil Reference - Voltage code = Order code

Example: 347N33 - 495905 C2

Valves and coils may be ordered also separately.

Coils 32 mm / 37 mm / 40 mm for N33-N34-N35 Series ATEX Solutions Zone 1-21

Ref. 483371 & 494040

ATEX Zone 1-21

These coils are suitable for use in Gas and Dust dangerous areas (**Zone 1-21**), according to the European directive **ATEX 94/9/C**. **Protection mode: encapsulated electrical parts with increased safety.**

Reference		483371 or HZ06	494040 or HZ23		
Approval		LCIE 02 ATEX 6011 X		LCIE 02 ATEX 6013 X	
Type of protection	Gas	II 2 G - Ex e mb II T4		II 2 G - Ex e mb II T3	
	Dust	II 2 D - Ex tD A21 T 130°C		II 2 D - Ex tD A21 T 195°C	
Degree of protection		IP67		IP67	
Ambiant temperature		-40°C to +65°C		-40°C to +90°C	
				-40°C to +65°C	
Class of insulation		F (155°)		H (180°)	
Electrical connection		By special cable gland or M20x1.5 "Ex e" on screw terminals for wires up to 1.5 mm ² . Cables with outside diameter 6.5 mm to 13.5 mm can be simply sealed using the rubber gland with resilient sealing rings supplied.			
Elect. Power	DC Pn (hot)	8 W		8 W	
	P (cold) 20°C	9 W		9 W	
	AC Pn (holding)	8 W		8 W	
		32 VA (9 W)		32 VA (9 W)	
Voltage tolerance		Tolerance -10/ +10% of the nominal voltage			
Solenoid duty		Continuous duty solenoid (ED 100%)			

Available Voltages	Order Code	Order Code
6 VDC	483371 C0	-
12 VDC	483371 C1	-
24 VDC	483371 C2	494040 C2
36 VDC	483371 C3	-
48 VDC	483371 C4	-
60 VDC	483371 M3	-
110 VDC	483371 C5	-
125 VDC	483371 3N	494040 3N
220 VDC	483371 C7	494040 C7
12/50 VAC	483371 A1	-
24/50 VAC	483371 A2	494040 A2
48/50 VAC	483371 A4	-
110-115/50 VAC	483371 0A	494040 0A
220-230/50	483371 3D	494040 3D
24/60 VAC	483371 B2	-
110-115/60 VAC	483371 6J	-
220-240/60 VAC	483371 4K	-
380/50-440/60 VAC	-	494040 5P

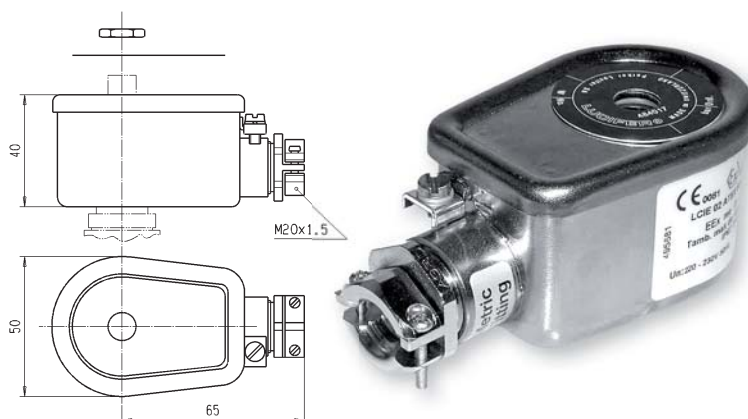

Fuses: Both electrical 483371... and 494040... parts have to be connected in series with a safety fuse according to CEI 60127-3.

483371...

DC: 24V / 400mA - 48V / 250mA
110V / 100mA

AC: 24V / 630mA - 48V / 315mA
110/115V / 160mA
220/230V / 80mA

494040...

DC: 24V / 400mA - 125V / 80mA
48V / 220V - 63mA

AC: 24V / 630mA - 48V / 315mA
110/115V / 160mA
220/230V / 80mA

How to Order

The housing kit is already included into the coil reference, so it's not needed to add it in the order code:

Valve Reference Number - Coil Reference - Voltage code = Order code

Example: 347N33 - 483371C2

Valves and coils may be ordered also separately.