

Valve Range

301LG Series - 3 Way Normally Closed From 301LG1..G2 to 301LG2..G2

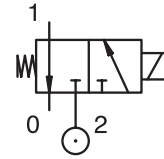

Port Size BSP	Orifice mm	Flow Factors		Operating Pressure Differential			Fluid Temperature		Seat Seal	Parker Valves		Power		Coil Group	Fluid Compatibility Class Column	Drawing N°
		kv l/min	Kv m³/h	Min. Bar	Max. (MOPD) AC bar	DC bar	Min. °C	Max. °C		Valve Ref.	Coil Ref.	AC W	DC W			
1/8"	1.5	1	0.06	0	8	8	-10	140	FKM	301LG1GVG2	DG	4	5	1.1/1.3	A	4
	2.5	2.3	0.14	0	3	3	-10	140	FKM	301LG1LVG2	DG	4	5	1.1/1.3	A	4
1/4"	1.5	1	0.06	0	8	8	-10	140	FKM	301LG2GVG2	DG	4	5	1.1/1.3	A	4
	2.5	2.3	0.14	0	3	3	-10	140	FKM	301LG2LVG2	DG	4	5	1.1/1.3	A	4
	1.5	1	0.06	0	12	12	-10	140	FKM	301LG2GVG7	D5	8	9	24/2.0	A	5
	3.0	4.5	0.27	0	4	4	-10	140	FKM	301LG2NVG7	D5	8	9	24/2.0	A	5

Nominal Pressure = 40 bar

NSF = all the references listed in this chart are NSF certified and use FDA compliant seals materials.

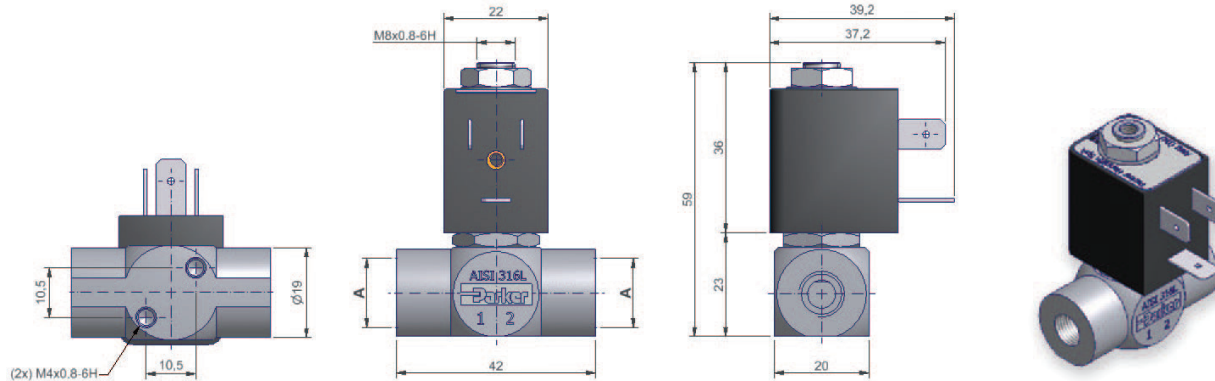

	Port Size A	Orifice mm	kv L/min	MOPD bar	Fluid Temp. °C	Amb. Temp. °C
From	1/8"	1.5	1.0	3	-10	-10
To	1/4"	2.5	2.3	8	140	50

All dimensions are in mm

Dimensional Drawing N°4

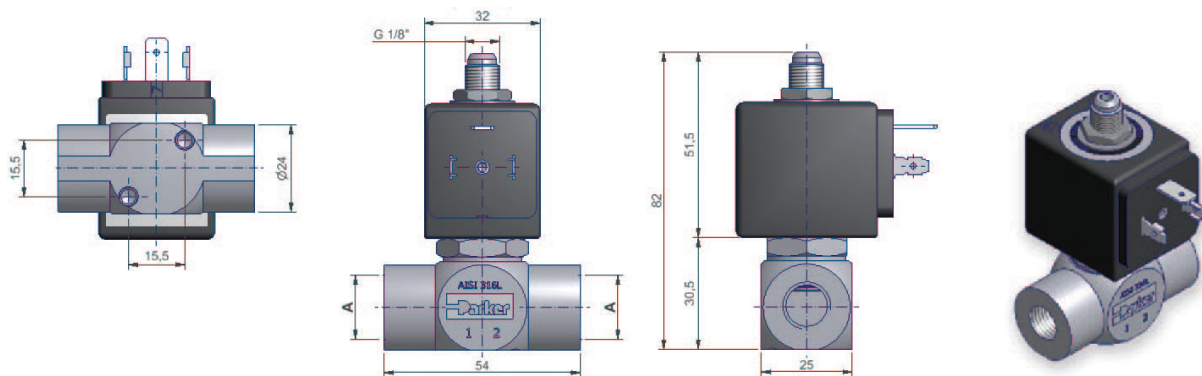

	Port Size A	Orifice mm	kv L/min	MOPD bar	Fluid Temp. °C	Amb. Temp. °C
From	1/4"	1.5	1	4	-10	-10
To		3.0	4.5	12	140	50

All dimensions are in mm

Dimensional Drawing N°5