

General Description

Series “MV” high-precision metering and shut-off valves allow extremely close control of fluids used in actuating and governing equipment.

Operation

The standard needle allows fine adjustment at low flow by using the first three turns of the adjusting knob; the next three turns open the valve to full flow, and also provide standard throttling adjustments.

Specifications

Maximum Operating Pressure	Brass: 140 Bar (2000 PSI); except for MV1600 brass which is 35 Bar (500 PSI) Steel: 345 Bar (5000 PSI) for MV200, 400, 600, 620, 800, 1020, 1200, 1220; 207 Bar (3000 PSI) for all other sizes and styles
Operating Temperature	-40°C to +121°C (-40°F to +250°F)

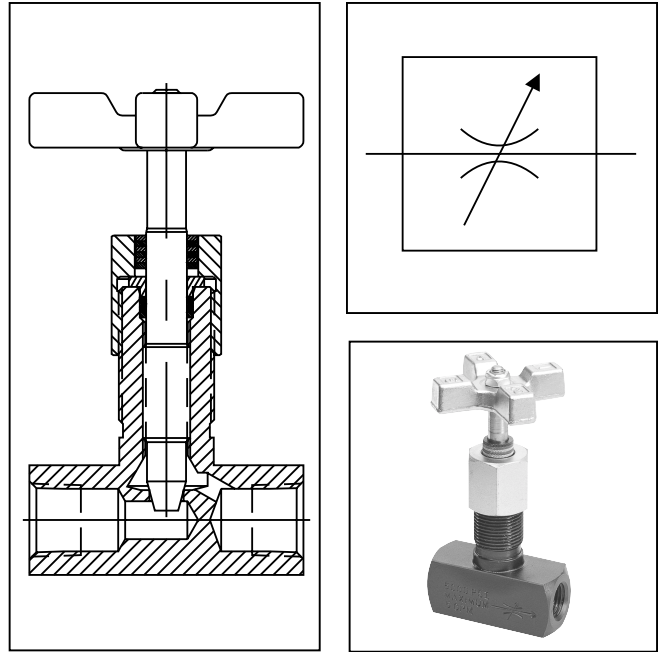

Features

- The exclusive “Colorflow” color-band reference scale on the valve stem is a great convenience and time-saver in setting the valve originally and in returning it to any previous setting.
- Fine and Micro-fine needles available for extremely fine control.
- MVK mounting kit makes panel mounting simple.
- High efficiency O-Ring stem seal that eliminates packing.

Performance Curves

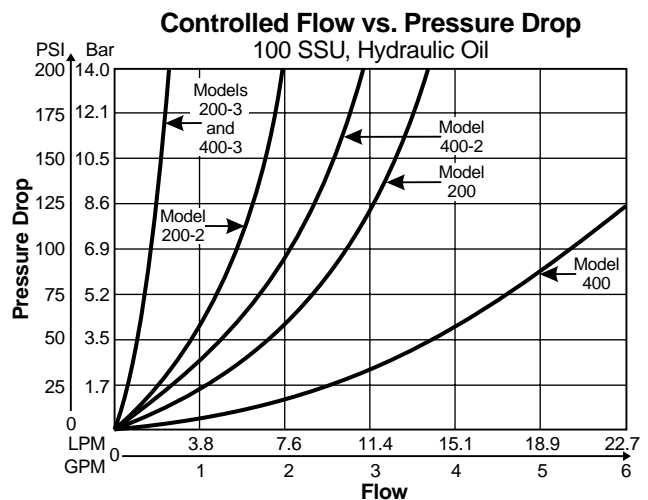
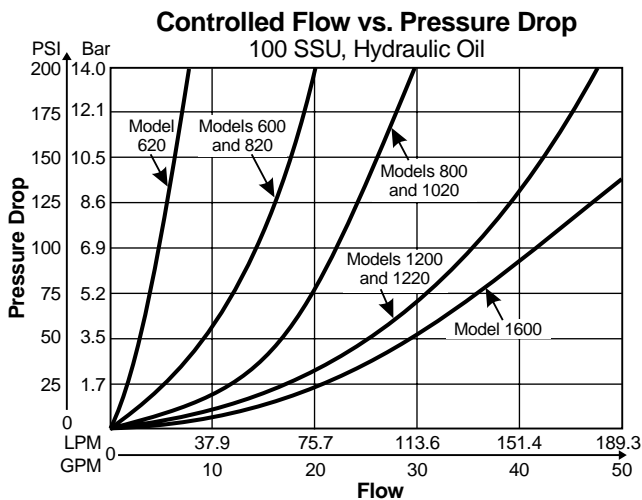

*Inch equivalents for millimeter dimensions are shown in (**)

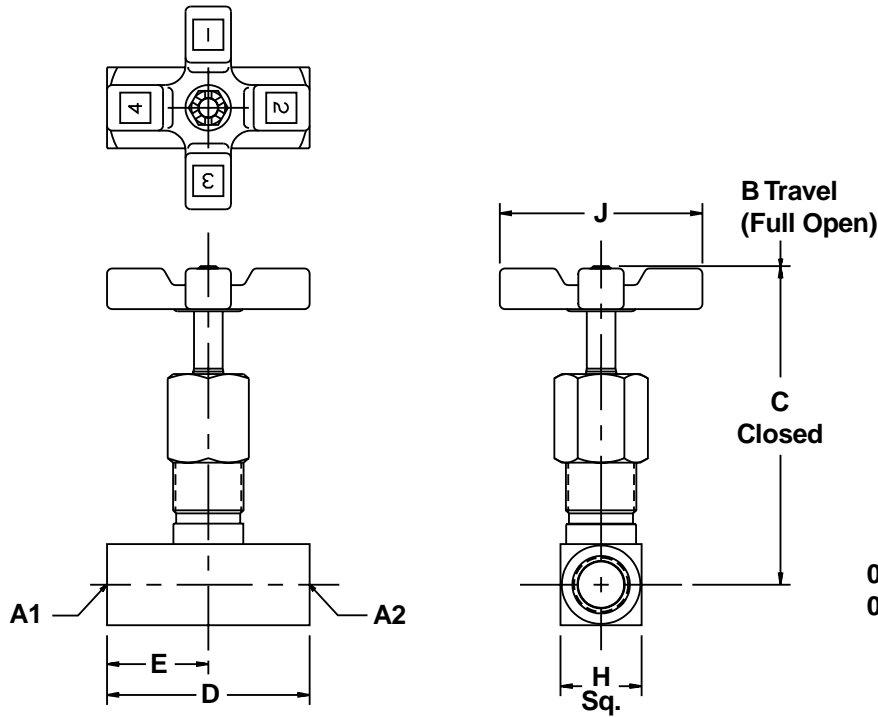

00 is female to female
 01 is female to male

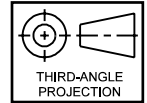

Model Number	A1	A2	B	C	D	E	F	H	J
MV200	1/8-27 NPTF Female	1/8-27 NPTF Female	69.1 (2.72)	63.8 (2.51)	38.1 (1.50)	19.1 (0.75)		15.7 (0.62)	44.5 (1.75)
MV400	1/4-18 NPTF Female	1/4-18 NPTF Female	86.9 (3.42)	81.5 (3.21)	50.8 (2.00)	25.4 (1.00)		20.6 (0.81)	50.8 (2.00)
MV401	1/4-18 NPTF Male	1/4-18 NPTF Female	86.9 (3.42)	81.5 (3.21)	55.4 (2.18)	30.0 (1.18)		20.6 (0.81)	50.8 (2.00)
MV620	9/16-18 UNF #6 SAE	9/16-18 UNF #6 SAE	89.2 (3.51)	83.8 (3.30)	60.5 (2.38)	30.2 (1.19)		25.4 (1.00)	50.8 (2.00)
MV600	3/8-18 NPTF Female	3/8-18 NPTF Female	99.6 (3.92)	91.9 (3.62)	63.5 (2.50)	31.8 (1.25)		25.4 (1.00)	63.5 (2.50)
MV601	3/8-18 NPTF Male	3/8-18 NPTF Female	99.6 (3.92)	91.9 (3.62)	68.1 (2.68)	36.3 (1.43)		25.4 (1.00)	63.5 (2.50)
MV820	3/4-16 UNF #8 SAE	3/4-16 UNF #8 SAE	108.7 (4.28)	101.1 (3.98)	76.2 (3.00)	38.1 (1.50)		28.4 (1.12)	63.5 (2.50)
MV800	1/2-14 NPTF Female	1/2-14 NPTF Female	129.3 (5.09)	116.6 (4.59)	66.5 (2.62)	33.3 (1.31)		31.8 (1.25)	82.6 (3.25)
MV1020	7/8-14 UNF #10 SAE	7/8-14 UNF #10 SAE	129.5 (5.10)	116.6 (4.59)	88.9 (3.50)	44.5 (1.75)		31.8 (1.25)	82.6 (3.25)
MV1200	3/4-14 NPTF Female	3/4-14 NPTF Female	141.8 (5.58)	127.8 (5.03)	82.6 (3.25)	41.1 (1.62)		38.1 (1.50)	98.6 (3.88)
MV1220	1 1/16-12 UNF #12 SAE	1 1/16-12 UNF #12 SAE	141.8 (5.58)	127.8 (5.03)	101.6 (4.00)	50.8 (2.00)		38.1 (1.50)	98.6 (3.88)
MV1600	1-11 1/2 NPTF Female	1-11 1/2 NPTF Female	146.8 (5.78)	132.8 (5.23)	108.0 (4.25)	53.8 (2.12)		44.5 (1.75)	98.6 (3.88)



*Inch equivalents for millimeter dimensions are shown in (**)

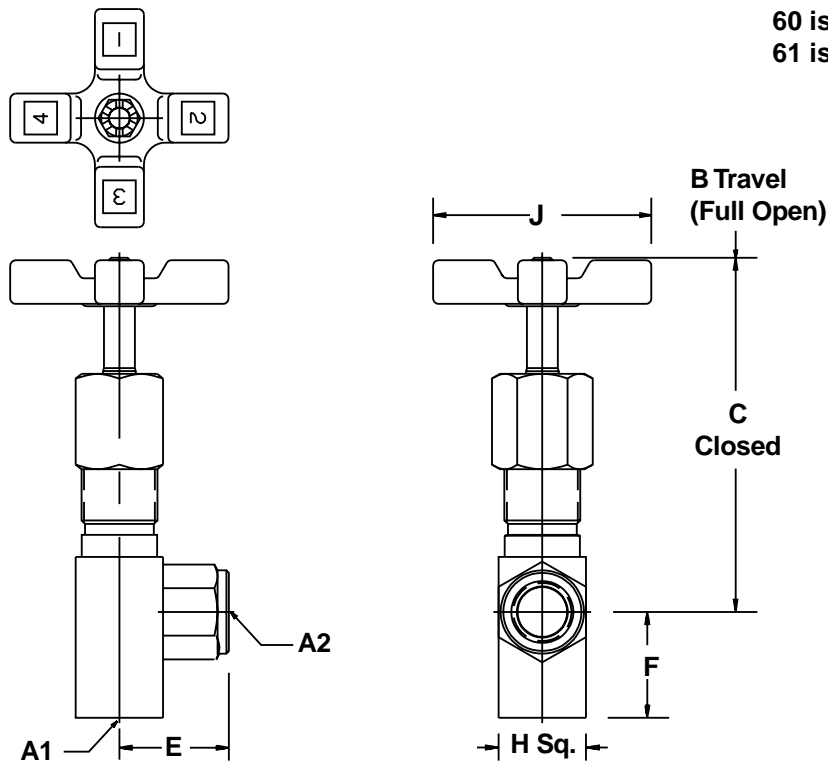

60 is Male to Female
61 is Female to Female

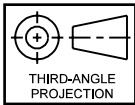

G

Model Number	A1	A2	B	C	D	E	F	H	J
MV260	1/8-27 NPTF Male	1/8-27 NPTF Female	72.4 (2.85)	67.1 (2.64)		19.1 (0.75)	22.1 (0.87)	15.7 (0.62)	44.5 (1.75)
MV460	1/4-18 NPTF Male	1/4-18 NPTF Female	90.2 (3.55)	84.8 (3.34)		27.2 (1.07)	30.7 (1.21)	20.6 (0.81)	50.8 (2.00)
MV660	3/8-18 NPTF Male	3/8-18 NPTF Female	110.7 (4.36)	103.1 (4.06)		31.8 (1.25)	34.8 (1.37)	25.4 (1.00)	63.5 (2.50)
MV860	1/2-14 NPTF Male	1/2-14 NPTF Female	133.4 (5.25)	120.7 (4.75)		36.8 (1.45)	42.7 (1.68)	31.8 (1.25)	82.6 (3.25)
MV261	1/8-27 NPTF Female	1/8-27 NPTF Female	72.4 (2.85)	67.1 (2.64)		19.1 (0.75)	20.6 (0.81)	15.7 (0.62)	44.5 (1.75)
MV461	1/4-18 NPTF Female	1/4-18 NPTF Female	90.2 (3.55)	84.8 (3.34)		27.2 (1.07)	27.7 (1.09)	20.6 (0.81)	50.8 2.00
MV661	3/8-18 NPTF Female	3/8-18 NPTF Female	110.7 (4.36)	103.1 (4.06)		31.8 (1.25)	30.7 (1.21)	25.4 (1.00)	63.5 (2.50)
MV861	1/2-14 NPTF Female	1/2-14 NPTF Female	133.4 (5.25)	120.7 (4.75)		36.8 (1.45)	38.1 (1.50)	31.8 (1.25)	82.6 (3.25)
MV1261	3/4-14 NPTF Female	3/4-14 NPTF Female	146.8 (5.78)	132.8 (5.23)		44.5 (1.75)	41.1 (1.62)	38.1 (1.50)	98.6 (3.88)

Mounting Kit

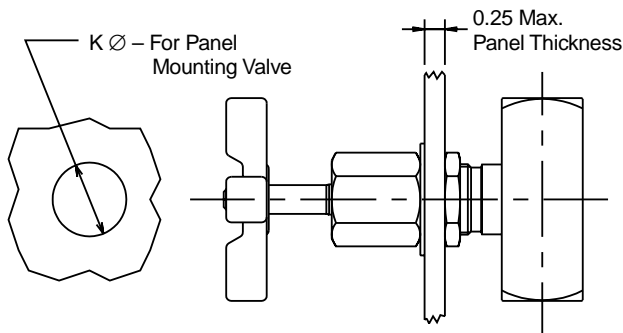

Panel Mounting Kits		
Kit Number	K	Valve Model
MVK2	15.0 (0.59)	MV200
MVK4	19.8 (0.78)	MV400 MV620
MVK6	23.1 (0.91)	MV600 MV820
MVK8	29.5 (1.16)	MV800 MV1020
MVK12	35.8 (1.41)	MV1200
MVK16	35.8 (1.41)	MV1600

Ordering Information

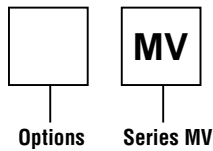

Code	Description
Omit	Standard
8	BSPT
9	BSPP



* 200	601	861
260	620	1020
261	660	1200
* 400	661	1220
401	* 800	1261
460	820	1600
461	860	1620
* 600		

* sizes available in Brass.

Code	Description
B	Brass
S	Steel

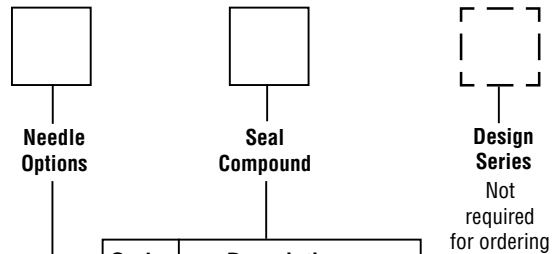

Code	Description
Omit	Nitrile (Standard)
V	Fluorocarbon (Optional)

Code	Description
Omit	Standard 30° Taper
2	Fine
3	Micro-fine

2 and 3 available only in Series 200 and 400

Model Number	Weight Kg (lbs.)	Model Number	Weight Kg (lbs.)
MV200	0.1 (0.3)	MV661	0.5 (1.2)
MV260	0.1 (0.3)	MV681	0.5 (1.2)
MV261	0.1 (0.3)	MV800	1.0 (2.1)
MV400	0.3 (0.7)	MV820	0.5 (1.2)
MV401	0.3 (0.7)	MV860	0.9 (2.0)
MV460	0.3 (0.7)	MV861	1.0 (2.1)
MV461	0.3 (0.6)	MV1020	1.0 (2.1)
MV600	0.5 (1.2)	MV1200	1.6 (3.50)
MV601	0.5 (1.1)	MV1221	1.6 (3.50)
MV620	0.5 (1.0)	MV1600	1.9 (4.20)
MV660	0.5 (1.2)	MV1620	1.9 (4.20)

An optional MKV mounting kit makes panel mounting quite simple.



General Description

Series “6MV” metering valves provide high-precision metering and shut-off.

Operation

The standard needle allows fine adjustment at low flow by using the first three turns of the adjusting knob; the next three turns open the valve to full flow, and also provide standard throttling adjustments.

Specifications

Maximum Operating Pressure	345 Bar (5000 PSI)		
Maximum Flow	M12 x 1.5	11 LPM (3 GPM)	
	M14 x 1.5	11 LPM (3 GPM)	
	M16 x 1.5	19 LPM (5 GPM)	
	M18 x 1.5	30 LPM (8 GPM)	
	M22 x 1.5	57 LPM (15 GPM)	
	M27 x 2.0	95 LPM (25 GPM)	
Material	Body	ASTM 12L14 Carbon Steel	
	Bonnet	ASTM 12L14 Carbon Steel	
	Knob	ASTM 12L14 Carbon Steel	
	Needle	ASTM 416 Stainless Steel	
	Handle	Zinc Die Cast	
Seals	Nitrile — Standard Fluorocarbon — Optional		

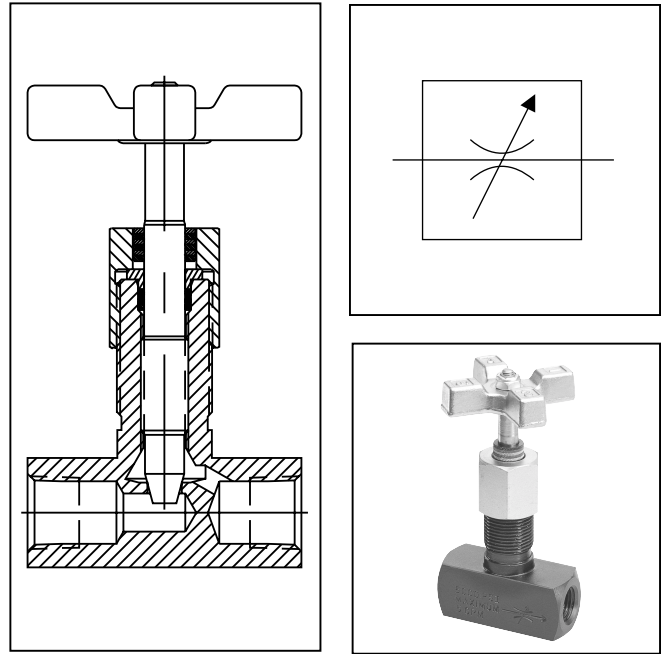

Features

- Meets ISO 6149 standards.
- Hard metric dimensions.
- Reliable leak-free performance — straight thread port with O-Ring sealing.
- Global interchangeability.

Performance Curves

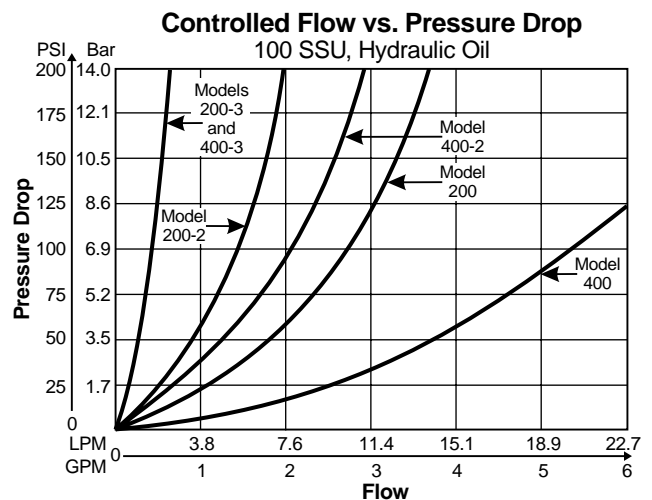
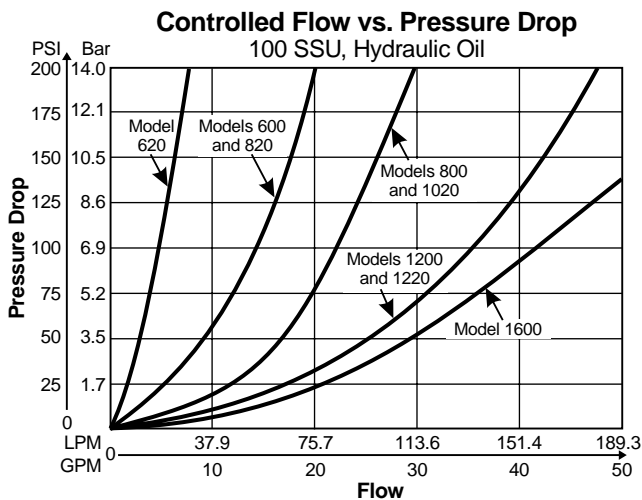

Dimensions

*Inch equivalents for millimeter dimensions are shown in (**)

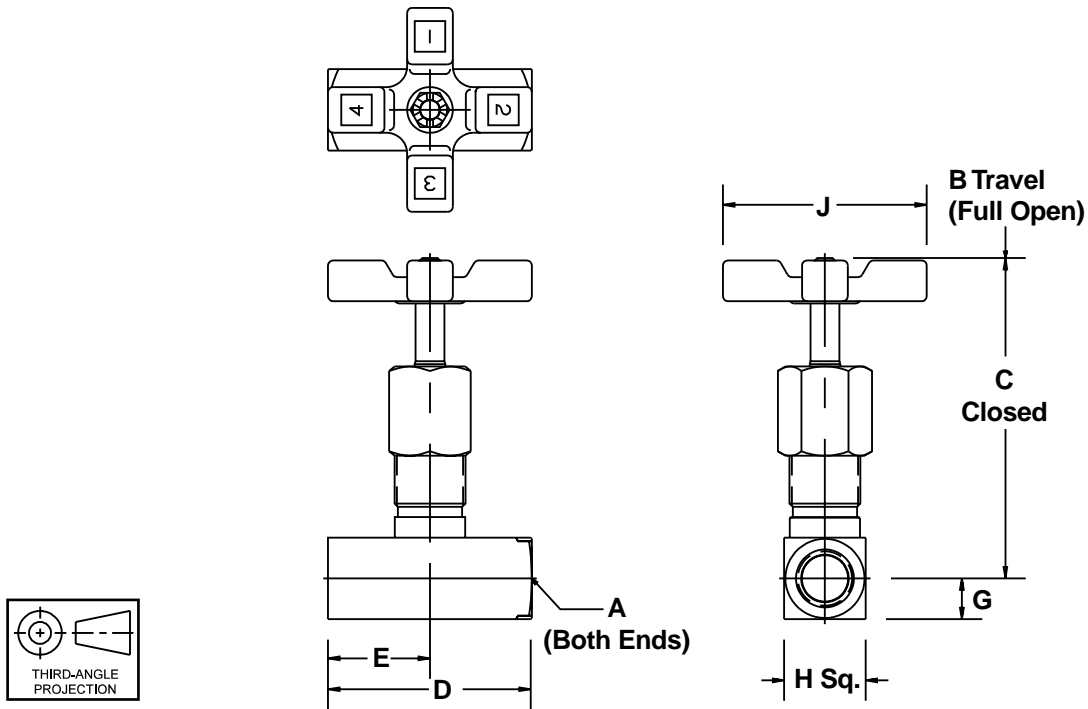

Model Number	A	B	C	D	E	F	G	H	J
6MV412	M12 x 1.5	86.9 (3.42)	81.5 (3.21)	50.8 (2.00)	25.4 (1.00)		10.4 (0.41)	20.6 (0.81)	50.8 (2.00)
6MV414	M14 x 1.5	86.9 (3.42)	81.5 (3.21)	50.8 (2.00)	25.4 (1.00)		10.4 (0.41)	20.6 (0.81)	50.8 (2.00)
6MV616S	M16 x 1.5	89.2 (3.51)	83.8 (3.30)	60.5 (2.38)	30.2 (1.19)		12.7 (0.50)	25.4 (1.00)	50.8 (2.00)
6MV818S	M18 x 1.5	108.7 (4.28)	101.1 (3.98)	76.2 (3.00)	38.1 (1.50)		14.2 (0.56)	28.4 (1.12)	63.5 (2.50)
6MV1022S	M22 x 1.5	129.3 (5.09)	116.6 (4.59)	88.9 (3.50)	44.5 (1.75)		15.7 (0.62)	31.8 (1.25)	82.6 (3.25)
6MV1227S	M27 x 2.0	141.7 (5.58)	127.8 (5.03)	101.6 (4.00)	50.8 (2.00)		19.1 (0.75)	38.1 (1.50)	98.6 (3.88)

Ordering Information

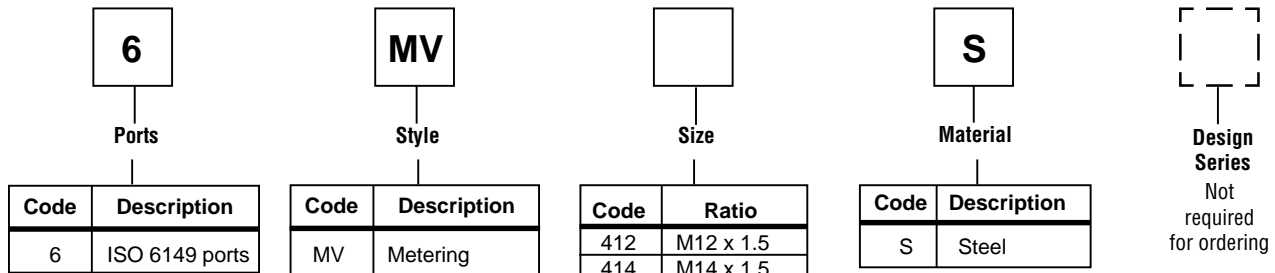

Model Number	Weight Kg (lbs.)	Model Number	Weight Kg (lbs.)
6MV412S	0.5 (1.0)	6MV818S	0.5 (1.2)
6MV414S	0.5 (1.0)	6MV1022S	1.0 (2.1)
6MV616S	0.5 (1.0)	6MV1227S	1.6 (3.5)