

P1D Standard

The innovative P1D is a future-proof generation of ISO/VDMA cylinders. The cylinders are double-acting, with a new design of air cushioning. The light, stiff body extrusion has sensor grooves for simple and protected sensor installation.

Installation dimensions according to international standards

The new P1D complies with the current ISO 6431, ISO 15552, VDMA 24562 and AFNOR installation dimension standards. For customer reassurance world-wide.

High technology design

The best materials, manufacturing methods and design of every detail have been carefully tested, to give the best possible product. The internal components are made of high strength plastics, for quiet operation and long service life. The aluminium end caps and the torsionally stiff aluminium body extrusion make the cylinder robust and suitable for a wide range of applications.

High quality

The P1D has been developed with quality in all phases – requirement specification, design, planning, purchasing, production, distribution and service. We have been certified under the ISO 9001 QA standard for the past ten years. Quality in all our products and services is our watchword.

Even more functions and variants

The P1D is available with all the usual optional designs, such as: Through piston rod, high and low temperature, hydraulic operation, extended piston rod etc.

A new special variant is the unique self-lubricating HDPE scraper ring and piston rod seal, specially designed for operation with a completely dry piston rod (i.e. applications where the film of grease on the piston rod is regularly washed off).

Cylinder forces, double acting variants

Cyl. bore/ pist. rod mm	Stroke	Pistonarea cm ²	Max theoretical force in N (bar)									
			1,0	2,0	3,0	4,0	5,0	6,0	7,0	8,0	9,0	10,0
32/12	+	8,0	80	161	241	322	402	483	563	643	724	804
	-	6,9	69	138	207	276	346	415	484	553	622	691
40/16	+	12,6	126	251	377	503	628	754	880	1005	1131	1257
	-	10,6	106	212	318	424	530	636	742	848	954	1060
50/20	+	19,6	196	393	589	785	982	1178	1374	1571	1767	1963
	-	16,5	165	330	495	660	825	990	1155	1319	1484	1649
63/20	+	31,2	312	623	935	1247	1559	1870	2182	2494	2806	3117
	-	28,0	280	561	841	1121	1402	1682	1962	2242	2523	2803
80/25	+	50,3	503	1005	1508	2011	2513	3016	3519	4021	4524	5027
	-	45,4	454	907	1361	1814	2268	2721	3175	3629	4082	4536
100/25	+	78,5	785	1571	2356	3142	3927	4712	5498	6283	7069	7854
	-	73,6	736	1473	2209	2945	3682	4418	5154	5890	6627	7363
125/32	+	122,7	1227	2454	3682	4909	6136	7363	8590	9817	11045	12272
	-	114,7	1147	2294	3440	4587	5734	6881	8027	9174	10321	11468

+ = Outward stroke
- = Return stroke

Note!

Select a theoretical force 50-100% larger than the force required

Main data: P1D

Cylinder designation	Cylinder		Piston rod		Cushioning length	Air consumption ²⁾ litre	Connection thread	Flexible Porting tubing dimension Push-in mm	
	bore	area	dia.	area					
	mm	cm ²	mm	cm ²	mm				
P1D-•032••-XXXX ¹⁾	32	8,0	12	1,1	M10x1,25	17	0,105	G1/8	4 or 6
P1D-•040••-XXXX ¹⁾	40	12,6	16	2,0	M12x1,25	19	0,162	G1/4	4 or 6
P1D-•050••-XXXX ¹⁾	50	19,6	20	3,1	M16x1,5	20	0,253	G1/4	8 or 10
P1D-•063••-XXXX ¹⁾	63	31,2	20	3,1	M16x1,5	23	0,414	G3/8	8 or 10
P1D-•080••-XXXX ¹⁾	80	50,3	25	4,9	M20x1,5	23	0,669	G3/8	-
P1D-•100••-XXXX ¹⁾	100	78,5	25	4,9	M20x1,5	27	1,043	G1/2	-
P1D-•125••-XXXX ¹⁾	125	122,7	32	8,0	M27x2	30	1,662	G1/2	-

Total mass including moving parts

Cylinder designation	Total mass (kg) at 0 mm stroke			Supplement mass (kg) for rod locking All variants	Total mass (kg) Supplement per 10 mm stroke		
	Standard	Tie-Rod	Clean/Flex		Standard	Tie-Rod	Clean/Flex
P1D-•032••-X	0,55	0,54	0,60	0,31	0,023	0,022	0,047
P1D-•040••-X	0,80	0,79	0,88	0,44	0,033	0,030	0,063
P1D-•050••-X	1,20	1,20	1,32	0,61	0,048	0,048	0,094
P1D-•063••-X	1,73	1,73	1,86	1,25	0,051	0,051	0,101
P1D-•080••-X	2,45	2,47	2,63	2,45	0,075	0,079	0,142
P1D-•100••-X	4,00	4,00	4,22	3,72	0,084	0,084	0,168
P1D-•125••-X	6,87	6,73	7,01	6,07	0,138	0,129	0,248

Mass moving parts only (for cushioning calculation)

Cylinder designation	Mass moving parts(kg)	
	at 0 mm stroke All variants	Supplement per 10 mm stroke All variants
P1D-•032••-X	0,13	0,009
P1D-•040••-X	0,24	0,016
P1D-•050••-X	0,42	0,025
P1D-•063••-X	0,50	0,025
P1D-•080••-X	0,90	0,039
P1D-•100••-X	1,10	0,039
P1D-•125••-X	2,34	0,063

1) Stroke



2) Free air consumption per 10 mm stroke for a double stroke at 6 bar

Standard stroke

Standard strokes for all P1D cylinders comply with ISO 4393. (* 40 is not an ISO standard stroke)

Special strokes up to 2800 mm.

Minimum stroke for P1D Clean is 25 mm with 0-2 sensors and 100 mm with 3-4 sensors.

Order no XXXX = Stroke	Cylinder bore (mm)	● = Standard stroke (mm)											■ = Stroke to special order					
		25	40	50	80	100	125	160	200	250	320	400	500	600	700	800	2800	
Double acting																		
Profile cylinder																		
P1D-S032MS-XXXX	32		●	●	●	●	●	●	●	●	●	●	●	●	●	●	///	
P1D-S040MS-XXXX	40		●	●	●	●	●	●	●	●	●	●	●	●	●	●	///	
P1D-S050MS-XXXX	50		●	●	●	●	●	●	●	●	●	●	●	●	●	●	///	
P1D-S063MS-XXXX	63		●	●	●	●	●	●	●	●	●	●	●	●	●	●	///	
P1D-S080MS-XXXX	80		●	●	●	●	●	●	●	●	●	●	●	●	●	●	///	
P1D-S100MS-XXXX	100		●	●	●	●	●	●	●	●	●	●	●	●	●	●	///	
P1D-S125MS-XXXX	125		●	●	●	●	●	●	●	●	●	●	●	●	●	●	///	

Operation data

Working pressure	Max 10 bar	
Working temperature	min	max
Standard	-20 °C	+80 °C
High temp version	-10 °C	+150 °C
Low temp version	-40 °C	+80 °C

Greased for life, does not normally need additional lubrication. If extra lubrication is given, this must always be continued.

Working medium, air quality

Working medium Dry, filtered compressed air to ISO 8573-1 class 3.4.3.

Recommended air quality for cylinders

For best possible service life and trouble-free operation, ISO 8573-1 quality class 3.4.3 should be used. This means 5 µm filter (standard filter) dew point +3 °C for indoor operation (a lower dew point should be selected for outdoor operation) and oil concentration 1.0 mg oil/m³, which is what a standard compressor with a standard filter gives.

ISO 8573-1 quality classes

Quality class	Pollution particle size (µm)	max concentration (mg/m ³)	Water max. press. dew point (°C)	Oil max concentration (mg/m ³)
1	0,1	0,1	-70	0,01
2	1	1	-40	0,1
3	5	5	-20	1,0
4	15	8	+3	5,0
5	40	10	+7	25
6	-	-	+10	-

Bores and strokes

P1D	32 - 125 mm
Standard strokes	25 - 500 mm according to ISO 4393
Max stroke	2800 mm
Min stroke, P1D Clean	25 mm (0-2 sensors) 100 mm (3-4 sensors)

P1D Clean

Protection class	Hose-proof in accordance with IP65
Chemical resistance	Tested for normally used industrial detergents, both acid and alkaline

Low pressure hydraulic

Working pressure	Max 10 bar Min 2 bar
------------------	-------------------------

For low pressure hydraulic systems is following oil quality to be used.

Hydraulic oil type HLP (DIN 51524, ISO 11158).
Viscosity by 40 °C: 32 mm²/s (cSt).

For instance Shell Tellus 32 or equal.



Important!

If the cylinder is used in applications with significant lateral loads on the piston rod, an external guide must be used to achieve maximum service life. See the examples on pages 52-55.

Material specification

Standard design

Body extrusion	Natural colour, anodised aluminium
End cover	Black anodised aluminium
End cover inserts	POM
End cover nuts/screws	Zinc plated steel 8.8
Piston rod nut	Zinc plated steel
Piston rod	Stainless steel, X 10 CrNiS 18 9
Scraper ring	PUR
Piston rod bearing	POM
Piston	POM
Piston bearing	POM
Magnetic ring	Plastic bound magnetic material
Piston bolt	Zinc plated steel
Piston seal	PUR
O-rings	Nitrile rubber, NBR
End-of-stroke washers	PUR
Cushioning seals	PUR
Cushioning screws	LCP

P1D Clean

Transparent moulding	Silicone
Transparent cover	ABS
Screws, sensor system	Stainless steel, A2
Upper seal and lower seal, protective cover	Santopren
Sealing plugs	PA
Piston rod nut	Stainless steel, A2

P1D Flexible Porting

Connection part Ø32-63	POM
Elbow fittings Ø32-63	PA
Straight fittings on body extrusion Ø32-63	PA
Straight fittings in ports	Nickel plated brass
Seal, connection part	Nitrile rubber NBR

P1D Tie-Rod

Tie-rods	Stainless steel, X 10 CrNiS 18 9
----------	----------------------------------

Design variants

Low temperature design	
Seals/scraper ring	Polyurethane PUR/Nitrile rubber NBR
Piston	Anodised aluminium
Piston/piston rod bearing	UHMWPE plastic

High temperature design	
Seals/scraper ring	Fluorocarbon rubber, FPM
Piston	Anodised aluminium
Piston/piston rod bearing	Bronze filled PTFE

Low pressure hydraulics	
Seals/scraper ring	Nitrile rubber, NBR
Piston	Anodised aluminium
Piston/piston rod bearing	UHMWPE plastic

Cylinders for dry rod operation	
Seals/scraper ring	FPM/HDPE

Cylinder with metal scraper ring	
Scraper ring	Stainless steel/brass/NBR

Option	
Piston rod material	Hard-chromium plated steel, Fe 490-2 FN Acid-proof steel, X 5 CrNiMo 17 13 3 Hard-chromium plated stainless steel, X 10 CrNiS 18 9

Cushioning characteristics

The diagram below is used for dimensioning of cylinders related to the cushioning capacity. The maximum cushioning capacity shown in the diagram assumes the following:

- Low load, i.e. low pressure drop across the piston
- Equilibrium speed
- Correctly adjusted cushioning screw
- 6 bar at cylinder port

The load is the sum of internal and external friction, plus any gravitational forces. At high relative load (pressure drop exceeding 1 bar), we recommend that for any given speed, the mass should be reduced by a factor of 2.5, or for a given mass, the speed should be reduced by a factor of 1.5. This is in relation to the maximum performance given in the diagram

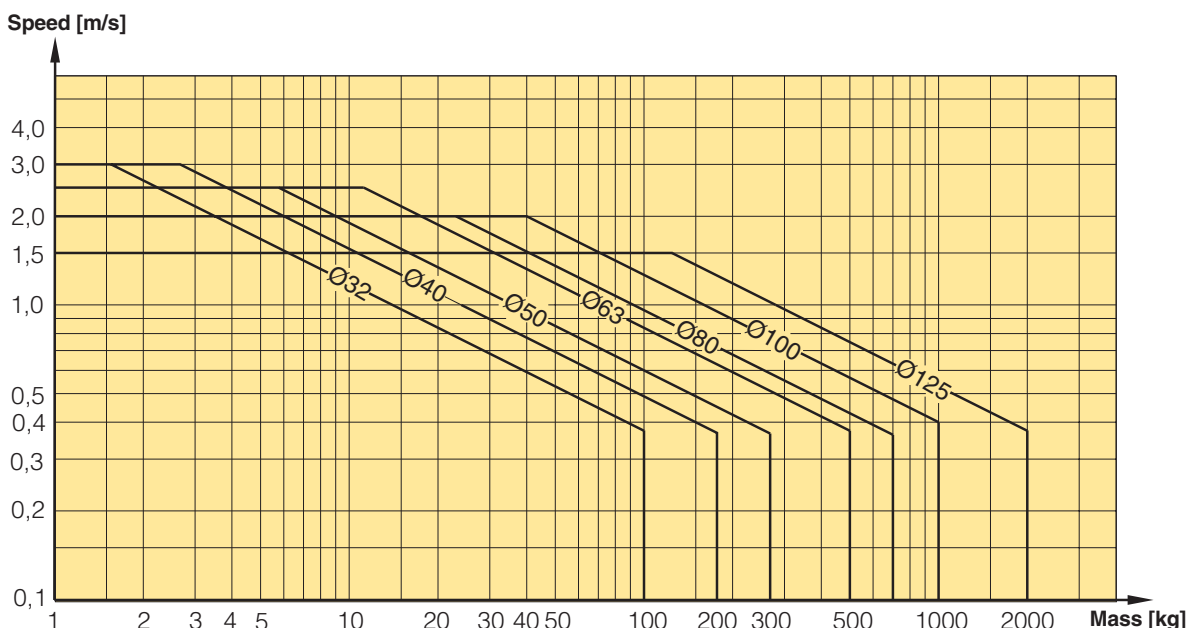

Guide for selecting suitable tubing

The selection of the correct size of tubing is often based on experience, with no great thought to optimizing energy efficiency and cylinder velocity. This is usually acceptable, but making a rough calculation can result in worthwhile economic gains.

The following is the basic principle:

1. The primary line to the working valve could be over sized (this does not cause any extra air consumption and consequently does not create any extra costs in operation).
2. The tubes between the valve and the cylinder should, however, be optimized according to the principle that an insufficient bore throttles the flow and thus limits the cylinder speed, while an oversized pipe creates a dead volume which increases the air consumption and filling time.

The chart below is intended to help when selecting the correct size of tube to use between the valve and the cylinder.

The following prerequisites apply:

The cylinder load should be about 50% of the theoretical force (= normal load). A lower load gives a higher velocity and vice versa. The tube size is selected as a function of the cylinder bore, the desired cylinder velocity and the tube length between the valve and the cylinder.

If you want to use the capacity of the valve to its maximum, and obtain maximum speed, the tubing should be chosen so that they at least correspond with the equivalent restriction diameter (see description below), so that the tubing does not restrict the total flow. This means that a short tubing must have at least the equivalent restriction diameter. If the tubing is longer, choose it from the table below. Straight fittings should be chosen for highest flow rates. (Elbow and banjo fittings cause restriction.)

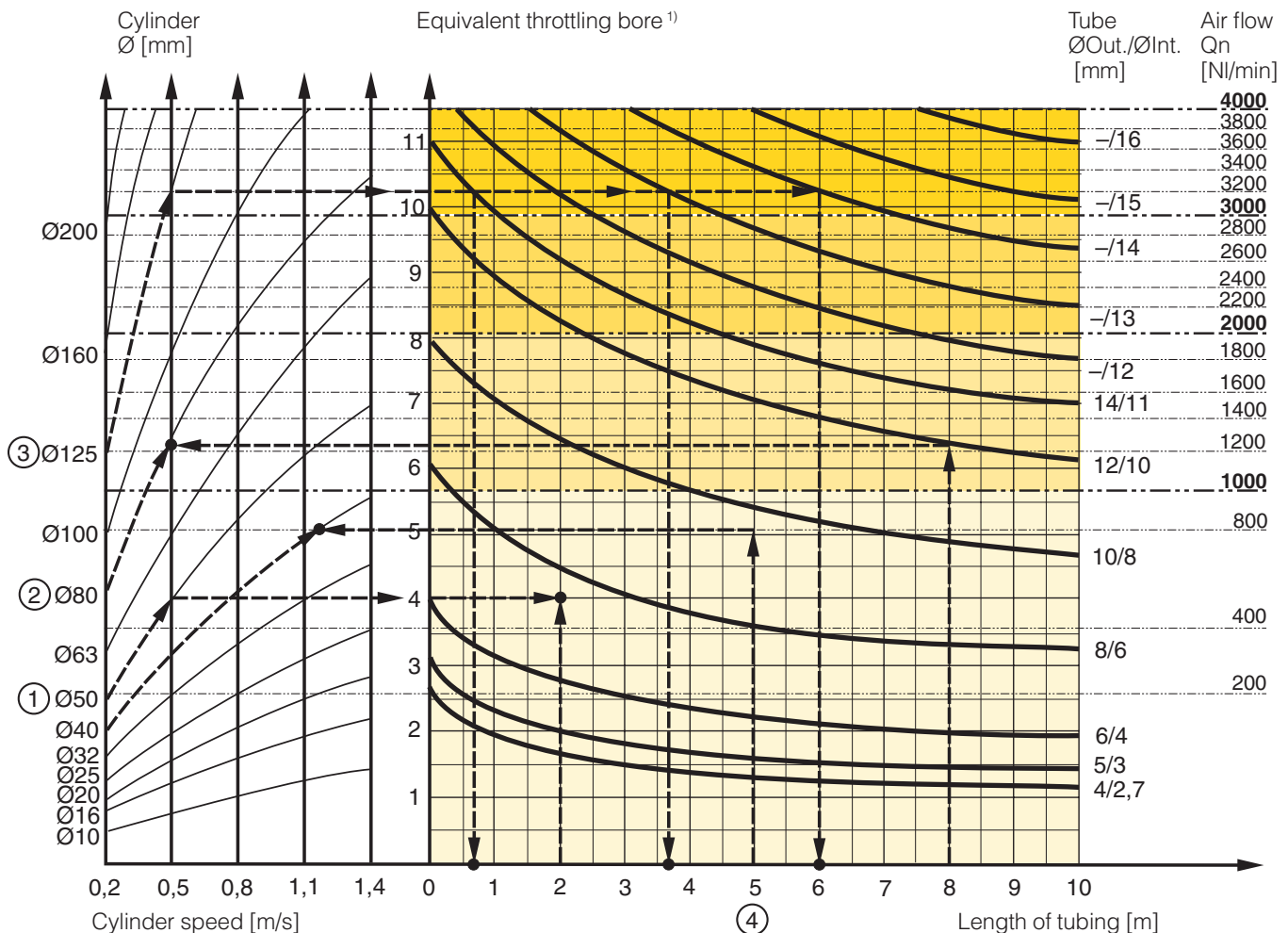

- 1) The "equivalent throttling bore" is a long throttle (for example a tube) or a series of throttles (for example, through a valve) converted to a short throttle which gives a corresponding flow rate. This should not be confused with the "orifice" which is sometimes specified for valves. The value for the orifice does not normally take account of the fact that the valve contains a number of throttles.
- 2) Qn is a measure of the valve flow capacity, with flow measured in litre per minute (l/min) at 6 bar(e) supply pressure and 1 bar pressure drop across the valve.

P1D Standard

CAD drawings on the Internet

Our home page www.parker.com/euro_pneumatic includes the AirCad Drawing Library with 2D and 3D drawings for the main versions.

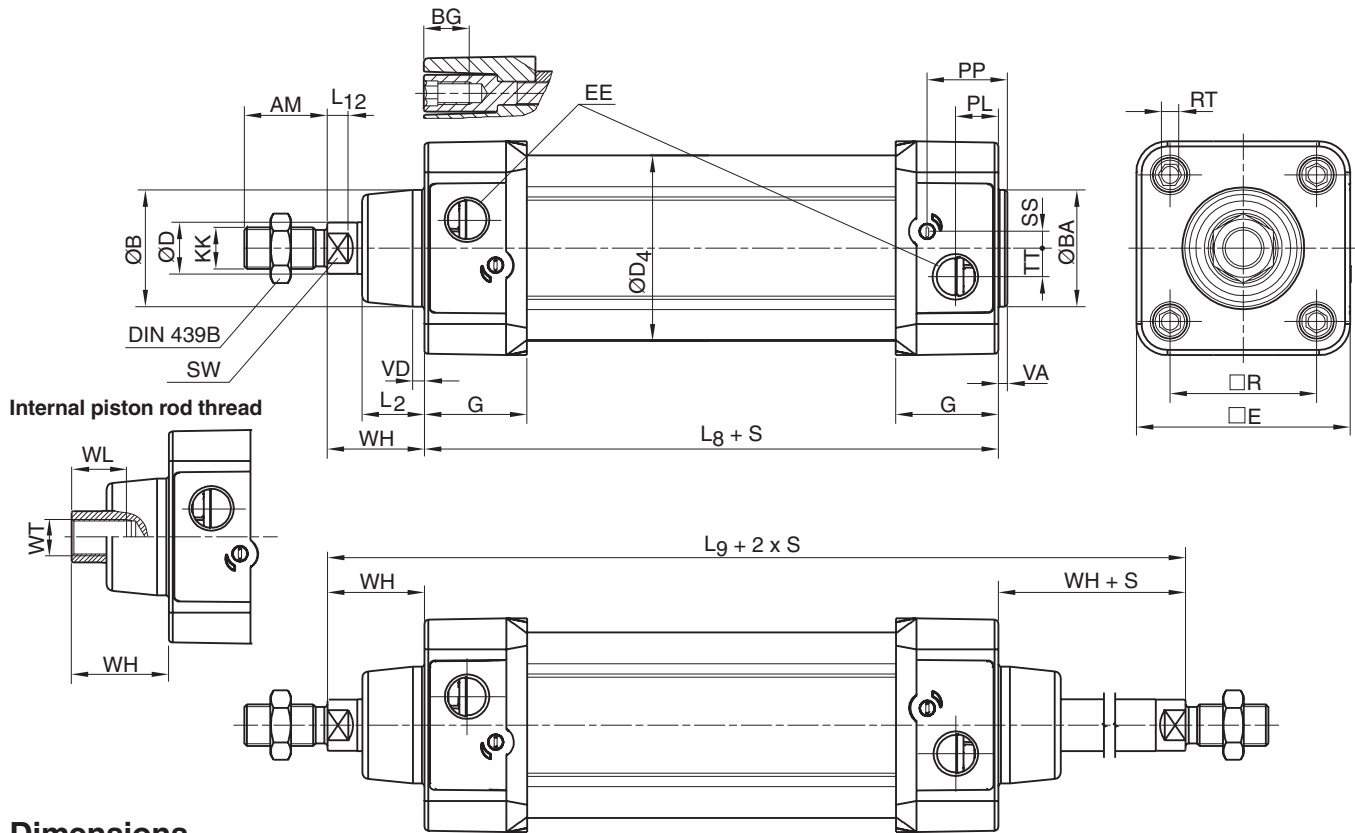

Dimensions

Cylinder bore mm	AM mm	B mm	BA mm	BG mm	D mm	D4 mm	E mm	EE mm	G mm	KK	L2 mm	L8 mm	L9 mm	L12 mm
32	22	30	30	16	12	45,0	50,0	G1/8	28,5	M10x1,25	16,0	94	146	6,0
40	24	35	35	16	16	52,0	57,4	G1/4	33,0	M12x1,25	19,0	105	165	6,5
50	32	40	40	16	20	60,7	69,4	G1/4	33,5	M16x1,5	24,0	106	180	8,0
63	32	45	45	16	20	71,5	82,4	G3/8	39,5	M16x1,5	24,0	121	195	8,0
80	40	45	45	17	25	86,7	99,4	G3/8	39,5	M20x1,5	30,0	128	220	10,0
100	40	55	55	17	25	106,7	116,0	G1/2	44,5	M20x1,5	32,4	138	240	14,0
125	54	60	60	20	32	134,0	139,0	G1/2	51,0	M27x2	45,0	160	290	18,0

Cylinder bore mm	PL mm	PP mm	R mm	RT	SS mm	SW mm	TT mm	VA mm	VD mm	WH mm	WL mm	WT
32	13,0	21,8	32,5	M6	4,0	10	4,5	3,5	4,5	26	21	M8x1
40	14,0	21,9	38,0	M6	8,0	13	5,5	3,5	4,5	30	23	M10x1,25
50	14,0	23,0	46,5	M8	4,0	17	7,5	3,5	5,0	37	31	M14x1,5
63	16,4	27,4	56,5	M8	6,5	17	11,0	3,5	5,0	37	31	M14x1,5
80	16,0	30,5	72,0	M10	0	22	15,0	3,5	4,0	46	39	M18x1,5
100	18,0	35,8	89,0	M10	0	22	20,0	3,5	4,0	51	39	M18x1,5
125	28,0	40,5	110,0	M12	0	27	17,5	5,5	6,0	65	53	M24x2

S=Stroke

Tolerances

Cylinder bore mm	B	BA	L _g mm	L _g mm	R mm	Stroke tolerance up to stroke 500 mm	Stroke tolerance for stroke over 500 mm
32	d11	d11	±0,4	±2	±0,5	+0,3/+2,0	+0,3/+3,0
40	d11	d11	±0,7	±2	±0,5	+0,3/+2,0	+0,3/+3,0
50	d11	d11	±0,7	±2	±0,6	+0,3/+2,0	+0,3/+3,0
63	d11	d11	±0,8	±2	±0,7	+0,3/+2,0	+0,3/+3,0
80	d11	d11	±0,8	±3	±0,7	+0,3/+2,0	+0,3/+3,0
100	d11	d11	±1,0	±3	±0,7	+0,3/+2,0	+0,3/+3,0
125	d11	d11	±1,0	±3	±1,1	+0,3/+2,0	+0,3/+3,0

P1D

Clean/Tie-Rod/Flexible Porting

P1D Clean

Minimum stroke for P1D Clean is 25 mm with 0-2 sensors and 100 mm with 3-4 sensors.

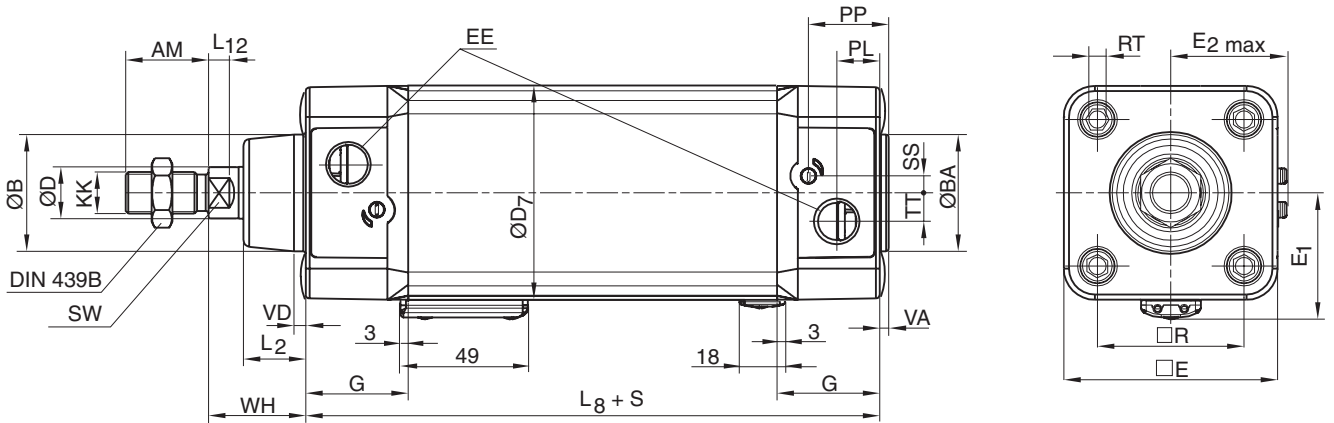

P1D Tie-Rod

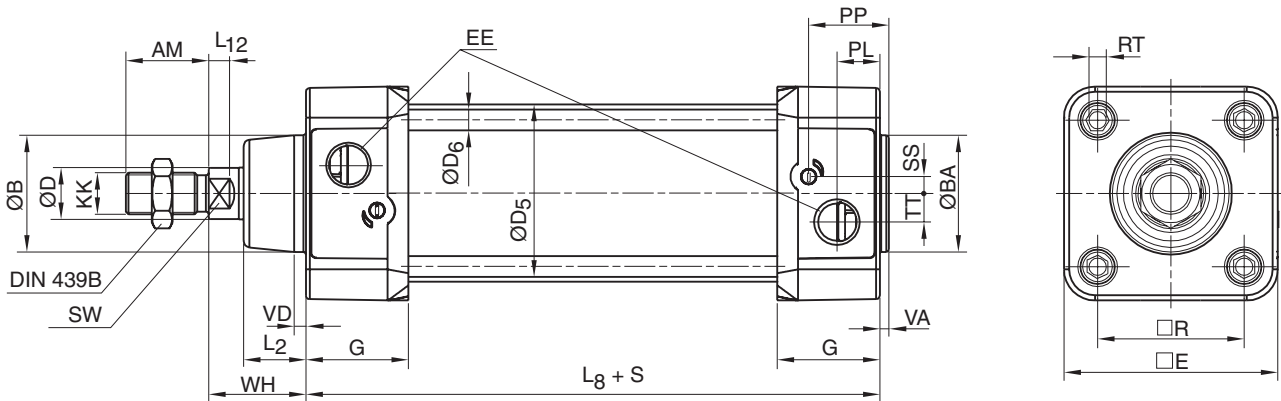

P1D Flexible Porting

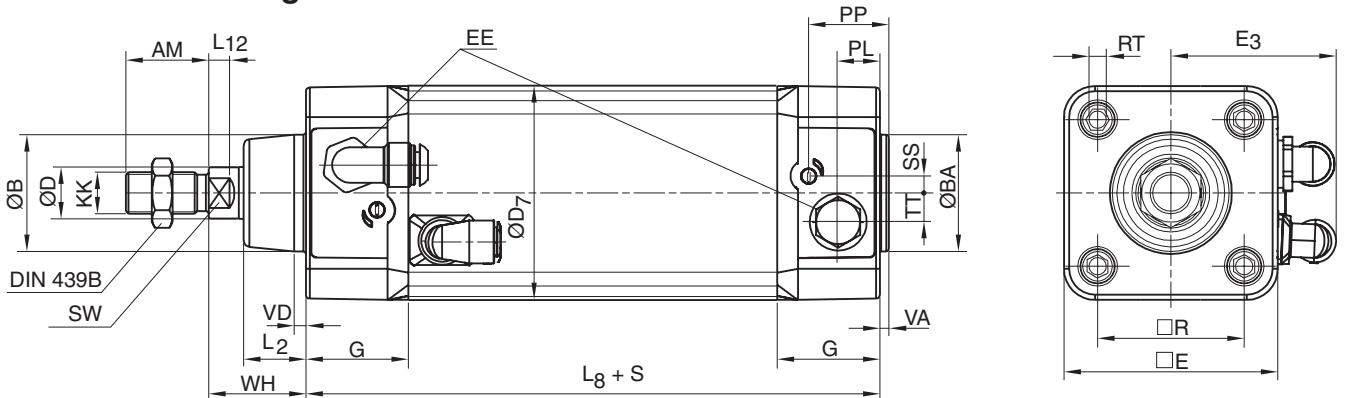

Dimensions

Cylinder bore						Elbow fittings, tubing \varnothing mm				Straight fittings, tubing \varnothing mm			
	D5	D6	D7	E1	E2max	4	6	8	10	4	6	8	10
	mm	mm	mm	mm	mm	E3	E3	E3	E3	E3	E3	E3	E3
32	36	5,3	49,6	32	30,0	42	44	-	-	38	40	-	-
40	44	5,3	57,3	36	34,7	46	48	-	-	42	44	-	-
50	55	7,1	69,3	42	40,7	-	-	56	76	-	-	48	50
63	68	7,1	82,3	49	46,2	-	-	64	83	-	-	55	75
80	86	8,9	99,3	57	54,7	-	-	-	-	-	-	-	-
100	106	8,9	117,6	68	64,0	-	-	-	-	-	-	-	-
125	132	10,8	142,8	81	75,5	-	-	-	-	-	-	-	-

Other dimensions, see opposite page

P1D Flexible Porting $\varnothing 80$ - $\varnothing 125$ can be ordered with threaded ports only or with factory-fitted elbow or straight push-in fittings (see position 20 in the order code key page 32)

The simple and complete order key

The P1D order key is based on the same principles as its predecessors, the P1C and P1E. This makes it easy to identify and order all common cylinder versions. The change-over from our previous cylinder ranges to the equivalent P1D cylinders is logical and simple. As far as possible, the same symbols as for P1C and P1E have been retained for the same functions. Most of the common cylinder types in the P1D-family have a 15-digit order number.

Many of our new cylinder versions, e.g. P1D Clean and P1D Flexible Porting, and complete working units (with factory-fitted cylinder mountings, sensors etc.) are defined by a 20-digit order number. There is only one single order key for P1D, which thus contains the 15-digit order numbers for the most common cylinder types and 20-digit order numbers for cylinders with more functions. Remember that there are always 15 or 20 positions in the order number – never any figure in between.



Valid for P1D-S***MS-****, see ATEX information pages 22 - 25.

1	2	3	4	5	6	7	8	9	10	11	12	13	14	15
P	1	D	-	S	0	3	2	M	S	-	0	1	0	0

Cylinder version	
S	Standard
C	Clean ²⁾
F	Flexible Porting
T	Tie-Rod

Stroke (mm)
e.g. 0100 = 100 mm
Optional stroke lengths up to 2800 mm. Standard strokes see table page 18

Cylinder bore mm
032
040
050
063
080
100
125

End cover screws		Function						
Standard	Stainless steel ²²⁾							
Std scraper	Metalavskrapare ²⁵⁾							
HDPE scraper ²³⁾	FPM sscraper ²⁶⁾							
Std scraper	Metalavskrapare ²⁵⁾							
HDPE scraper ²³⁾	FPM sscraper ²⁶⁾							
M	Q	D	V	A	S	H	W	Double-acting
F	R	E	B	G	T	Y	Z	Double-acting through rod
2	4	6	8	-	-	-	-	3 and 4 position cylinders
C	J	K	L	-	-	-	-	Tandem

Piston rod material		Seals		
Stainless steel	Chromium-plated steel	Acid-proof steel	Chrom.-pl. stainless steel	
S	C	M	R	Standard -20 °C to +80 °C.
F	G	N	D	High temperature version ⁶⁾ -10 °C to +150 °C. No magnetic function
L	K	P	E	Low temperature version ⁶⁾ -40 °C to +40 °C.
-	J	-	Z	Low pressure hydraulic ^{6) 24)}

2) P1D Clean without sensor function, see page 41.

6) For P1D-S and P1D-T.

22) If stainless steel end cover screws are selected, the piston rod nuts are also supplied in stainless steel.

23) For dry rod operation.

24) The seal system for low pressure hydraulics demands a hard chromed surface for proper function.

25) The metal scraper ring requires a hard-chromium plated piston rod

26) FPM scraper should be chosen for higher chemical resistance on standard temperature versions only.

Example 1 Standard, double acting cylinder

Standard cylinder with standard scraper ring (PUR), standard piston rod material (stainless steel) and standard temperature range.

P1D

P1D-S032MS-0160

P1D-S100MS-0400

Compare P1C and P1E

P1C-S032MS-0160

P1E-S032MS-0160

P1C-S100MS-0400

P1E-S100MS-0400

Example 2 Tie-Rod design, double acting cylinder

Tie-rod cylinder with standard scraper ring (PUR), hard chromed steel piston rod and standard temperature range.

P1D

P1D-T040MC-0125

Compare P1E

P1E-T040MC-0125

P1D Standard

The order numbers on this page refer to P1D Standard without sensors. The cylinders can be ordered with sensors, fittings, piston rod and cylinder mountings, speed controls etc. for efficient logistics. Please refer to the order key to select cylinders with factory-fitted accessories.



CE Ex II 2GD c T4 120 °C

See ATEX information pages 22 - 25.

P1D Standard

Double-acting

Cyl. bore mm	Stroke mm	Order code
32 Conn. G1/8	25	P1D-S032MS-0025
	40	P1D-S032MS-0040
	50	P1D-S032MS-0050
	80	P1D-S032MS-0080
	100	P1D-S032MS-0100
	125	P1D-S032MS-0125
	160	P1D-S032MS-0160
	200	P1D-S032MS-0200
	250	P1D-S032MS-0250
	320	P1D-S032MS-0320
40 Conn. G1/4	25	P1D-S040MS-0025
	40	P1D-S040MS-0040
	50	P1D-S040MS-0050
	80	P1D-S040MS-0080
	100	P1D-S040MS-0100
	125	P1D-S040MS-0125
	160	P1D-S040MS-0160
	200	P1D-S040MS-0200
	250	P1D-S040MS-0250
	320	P1D-S040MS-0320
50 Conn. G1/4	25	P1D-S050MS-0025
	40	P1D-S050MS-0040
	50	P1D-S050MS-0050
	80	P1D-S050MS-0080
	100	P1D-S050MS-0100
	125	P1D-S050MS-0125
	160	P1D-S050MS-0160
	200	P1D-S050MS-0200
	250	P1D-S050MS-0250
	320	P1D-S050MS-0320
63 Conn. G3/8	25	P1D-S063MS-0025
	40	P1D-S063MS-0040
	50	P1D-S063MS-0050
	80	P1D-S063MS-0080
	100	P1D-S063MS-0100
	125	P1D-S063MS-0125
	160	P1D-S063MS-0160
	200	P1D-S063MS-0200
	250	P1D-S063MS-0250
	320	P1D-S063MS-0320
80 Conn. G3/8	25	P1D-S080MS-0025
	40	P1D-S080MS-0040
	50	P1D-S080MS-0050
	80	P1D-S080MS-0080
	100	P1D-S080MS-0100
	125	P1D-S080MS-0125
	160	P1D-S080MS-0160
	200	P1D-S080MS-0200
	250	P1D-S080MS-0250
	320	P1D-S080MS-0320
100 Conn. G1/2	25	P1D-S100MS-0025
	40	P1D-S100MS-0040
	50	P1D-S100MS-0050
	80	P1D-S100MS-0080
	100	P1D-S100MS-0100
	125	P1D-S100MS-0125
	160	P1D-S100MS-0160
	200	P1D-S100MS-0200
	250	P1D-S100MS-0250
	320	P1D-S100MS-0320
125 Conn. G1/2	25	P1D-S125MS-0025
	40	P1D-S125MS-0040
	50	P1D-S125MS-0050
	80	P1D-S125MS-0080
	100	P1D-S125MS-0100
	125	P1D-S125MS-0125
	160	P1D-S125MS-0160
	200	P1D-S125MS-0200
	250	P1D-S125MS-0250
	320	P1D-S125MS-0320

P1D Standard

Double-acting

Cyl. bore mm	Stroke mm	Order code
80 Conn. G3/8	25	P1D-S080MS-0025
	40	P1D-S080MS-0040
	50	P1D-S080MS-0050
	80	P1D-S080MS-0080
	100	P1D-S080MS-0100
	125	P1D-S080MS-0125
	160	P1D-S080MS-0160
	200	P1D-S080MS-0200
	250	P1D-S080MS-0250
	320	P1D-S080MS-0320
100 Conn. G1/2	25	P1D-S100MS-0025
	40	P1D-S100MS-0040
	50	P1D-S100MS-0050
	80	P1D-S100MS-0080
	100	P1D-S100MS-0100
	125	P1D-S100MS-0125
	160	P1D-S100MS-0160
	200	P1D-S100MS-0200
	250	P1D-S100MS-0250
	320	P1D-S100MS-0320
125 Conn. G1/2	25	P1D-S125MS-0025
	40	P1D-S125MS-0040
	50	P1D-S125MS-0050
	80	P1D-S125MS-0080
	100	P1D-S125MS-0100
	125	P1D-S125MS-0125
	160	P1D-S125MS-0160
	200	P1D-S125MS-0200
	250	P1D-S125MS-0250
	320	P1D-S125MS-0320

The cylinders are supplied complete with one zinc plated steel piston rod nut.