



**SPECIFICATION:**

- 3-piece-body full bore
- Adjustable gland packing without removing actuators
- Investment casting body A351 Gr-CF8M
- Blow-out-proof stem
- ISO 5211 DIN3337 direct mounting pad
- Working pressure up to 1000psi W.O.G
- Working temperature up to 180° C

**PRESSURE TEST**

BODY	SEAT	
by water	by water	by air
105 kg/cm <sup>2</sup>	80 kg/cm <sup>2</sup>	6 kg/cm <sup>2</sup>

- Dome indicator for valve opening and closing positions

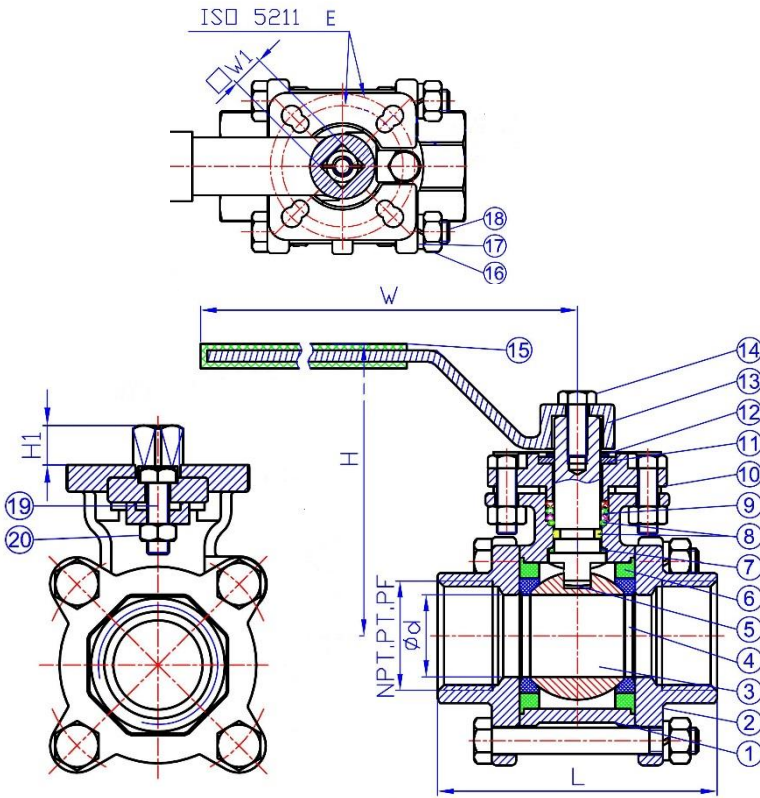

**MATERIAL LIST**

NO.	PART NAME	MATERIAL
1	Body	CF8M
2	Cap	CF8M
3	Ball	CF8M
4	Seat	R-PTFE
5	Stem	SUS316
6	Gasket	PTFE
7	Washer	PEEK+PTFE
8	O-ring	VITON
9	Packing	PTFE
10	Gland	CF8
11	Stopper	SUS304
12	Snap ring	SUS304
13	Locking	CF8
14	Bolt	SUS304
15	Handle Sleeve	PLASTIC
16	Joint nut	SUS304
17	Spring washer	SUS304
18	Joint bolt	SUS304
19	Bolt	SUS304
20	Nut	SUS304

**DIMENSIONS**

SIZE		L	H	W	H1	W1	Ø E	ISO5211	ACTUATOR	
G	d								DOUBLE ACTING	SPRING RETURN
1/4	11.6	63	74	123	9	9x9	36-42	F03-F04	AD 40N	AS 50N
3/8	12.7	63	74	123	9	9x9	36-42	F03-F04	AD 40N	AS 50N
1/2	15	63	74	123	9	9x9	36-42	F03-F04	AD 40N	AS 50N
3/4	20	73	78	123	9	9x9	36-42	F03-F04	AD 40N	AS 50N
1	25	85	89	153	11	11x11	42-50	F04-F05	AD 50N	AS 65N
1-1/4	32	96	94	153	11	11x11	42-50	F04-F05	AD 50N	AS 65N
1-1/2	38	114	110	183	14	14x14	50-70	F05-F07	AD 65N	AS 65N
2	50	134	118	183	14	14x14	50-70	F05-F07	AD 65N	AS 65N
2-1/2	65	180	161	352	17	17x17	70-102	F07-F10	AD 80N	AS 80N
3	80	200	170	352	17	17x17	70-102	F07-F10	AD 80N	AS 80N
4	100	228	202	397	22	22x22	102-125	F10-F12	AD 100N	AS 100N

The specification and dimensions are subject to change without prior notice!