



AT1000S

AT1000L

DESCRIPTION:

AUTOMA Safety Relieve Valve is used to control or limit the pressure or vessel which can build up by a process upset, instrument or equipment failure. It is designed to relieving excess pressure when line pressure is above the adjustable set pressure.

- Options for PTFE seat
- Working fluid: hot water, steam, gas and non-corrosive fluid

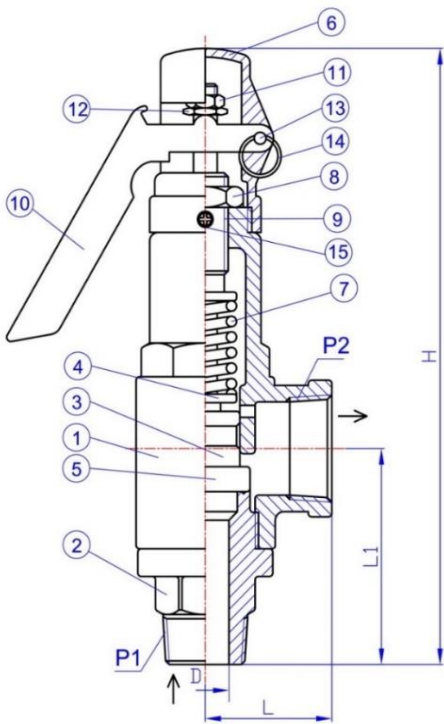

MATERIAL LIST:

PART NAME	MATERIAL	
	AT1000S	AT1000L
1.Body	Casting Bronze	Casting Bronze
2.Seat	Forging Brass	Forging Brass
3.Spindle	Brass	Brass
4.Spring seat	Brass	Brass
5.Disc	Forging Brass	Forging Brass
6.Cap	Casting Bronze	Brass
7.Spring	Steel	Steel
8.Adjusting nut	Brass	Brass
9.Adjusting rod	Brass	Brass
10.Handle	N/A	Steel
11.Hexagon nut	N/A	Steel
12.Stopper	N/A	Brass
13.Insert pin	N/A	Steel
14.Clip	N/A	Steel
15.Fixture screw	N/A	Steel

DIMENSIONS (mm):

D	SIZE		L	L1	H	
	P1	P2			AT1000S	AT1000L
13	1/2"	1/2"	29	51	139	162
19	3/4"	3/4"	36	56	150	174
25	1"	1"	40	71	182	202
32	1-1/4"	1-1/4"	51	83	208	222
38	1-1/2"	1-1/2"	55	94	233	247
50	2"	2"	67	103	266	287

The specification and dimensions are subject to change without prior notice!