

# GP General Purpose Valve - Series GPW



## 2/2-way Forced Lifting, Normally Closed

### Function:

Non-energised closed by spring power (NC)

When energised, the plunger opens the pilot orifice, relieving pressure from the top of the diaphragm via the outlet side of the valve. The line pressure then opens the valve by lifting the diaphragm off the main orifice.

### Compatible Fluids:

Air, Inert Gases, Water, Hydraulic Fluids, Petroleum Products and additional fluids compatible with materials of construction

### Installation:

The valves can be mounted in any position. It is however recommended to install them with the coil in vertical position above the body.

### Notes:

We recommend to install a strainer or filter before the valve if fluid is contaminated

Body Material: Forged Brass

Sealing Material: NBR

Pressure Range: 0~10bar

### Fluid Temperature:

NBR 85° C

Ambient 50° C

Enclosure: DIN43650A, IP65

### Voltage Available:

AC 24, 48, 110, 240V 50Hz

DC 12, 24V=

Tolerance +/- 10%

### Power Consumption DIN COIL:

AB410 AC-22VA, DC-18W

AB510 AC-28VA, DC-24W

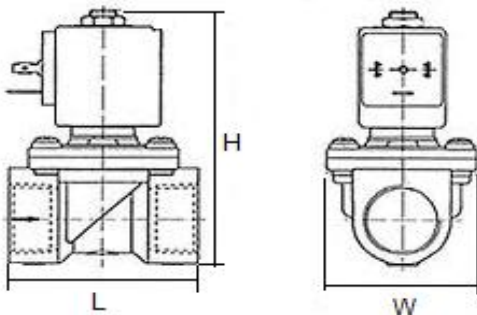

### DIN 43650A coil (IP65):

Solenoid coil is fitted with LED plug + varistor (VDR) to protect supply switch from inductive voltage spikes, and protect coil from burn-out.

Port Size G	Orifice (mm)	Part Number	Cv Value	Pressure Differential (bar)			Dimensions		
				Min	Max		L (mm)	W (mm)	H (mm)
					AC	DC			
1/2	15	GPW-20	4.8	0	10	10	60	45	111
3/4	20		7.6	0	10	10	62	50	117
1	25		12	0	10	10	82	66	124
1 1/4	32		24	0	7	7	102	82	156
1 1/2	40	GPW-50	29	0	7	7	110	85	161
2	50		48	0	7	7	134	108	176

Options:

*All technical specifications are without obligation!*

- Viton sealing suitable for gas, oil, hot water, acid, alkali, chemical salt, hydrocarbon up to max 110° C