



PNEUMATIC ACTUATOR



Design and Construction

- **AUTOMA Actuator** is designed for rotary type valve.
- **AUTOMA** provides various size of actuator, including heavy-duty actuator, to meet the customer's needs.
- **AUTOMA** is in accordance with **NAMUR** and **ISO Standard** which enable us to fit with valves & accessories easily & simply.
- **AUTOMA** is specialized in providing a wide range of industrial solutions such as petrochemical, power generation, atomic power plant, steel mill, shipyard, refining, wastewater disposal, automation facilities and building air conditioner.

Specification

- **Operating Pressure Range**
Double Acting : 4~7kg/cm²
Single Acting : 4.5~7kg/cm²
- **Operating Temperature Range**
Standard : -20°C ~ 80°C
Option : -40°C ~ 200°C
- **Cycle Life**
1,300,000 Operating
- **Rotating angle range**

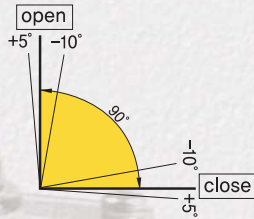

Model Selection Guide



- 1
AD Actuator Type
AD : Double Acting (Scotch-Yoke Type)
AS : Single Acting (Scotch-Yoke Type)
ADR : Double Acting (Rack&Pinion Type)
ASR : Single Acting (Rack&Pinion Type)

- 2
50 Actuator Size
AD : 50/65/80/100/125/140/160/185/200/250/300
AS : 50/65/80/100/125/140/160/185/200/250/300
ADR : 32/40/50/65/80/90/100/115/125/140/160/185/200
ASR : 40/50/65/80/90/100/115/125/140/160/185/200

INDEX

- 03 SCOTCH YOKE TYPE ACTUATOR
 - AD SERIES (DOUBLE ACTING)
 - AS SERIES (SINGLE ACTING)
 - TECHNICAL DATA
- 07 RACK&PINION TYPE ACTUATOR
 - ADR SERIES (DOUBLE ACTING)
 - ASR SERIES (SINGLE ACTING)
 - TECHNICAL DATA
- 11 HEAVY-DUTY ACTUATOR

SCOTCH YOKE TYPE ACTUATOR

Features

- The Side Direction
 - Side Handle
 - Middle Torque Spring
 - Strong Torque Spring
- The Back Direction
 - Stopper Bolt
 - 5° ~ 95° Stopper
- The Top Direction
 - Position Indicator
 - Limit Switch Box
 - Proximity Sensor
 - E/P Positioner
 - Position Transmitter
 - Manual Lever
- The Front Direction
 - Solenoid Valve (NAMUR)
 - Lock Up Valve
 - Volume Booster
 - Direct Fitting Assembler
- The Bottom Direction
 - Valve Mounting
 - Manual Handle
 - ISO 5211 DIN 3337 Square & Holes

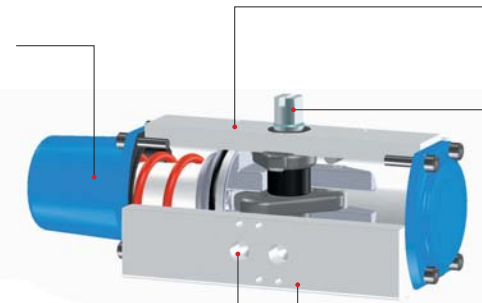

Part List

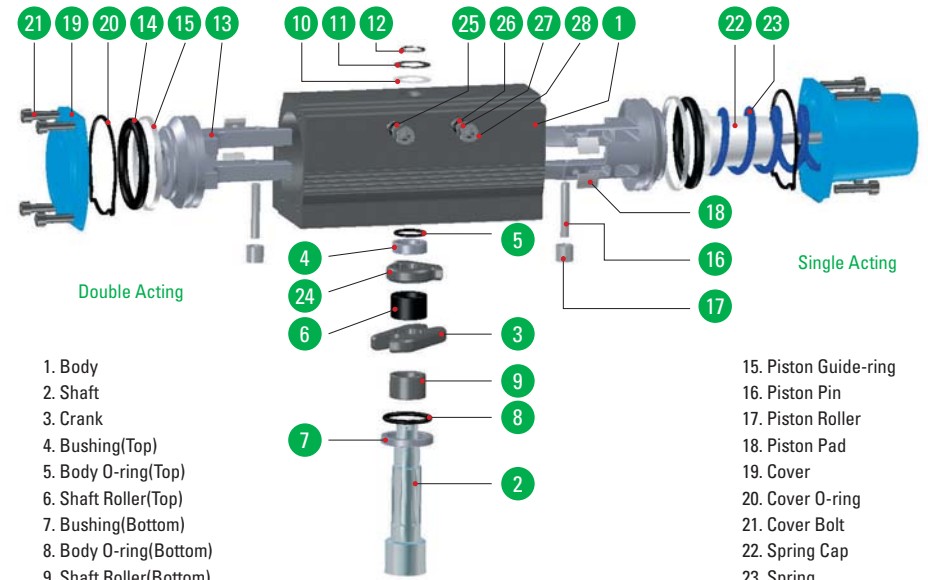

1. Body
2. Shaft
3. Crank
4. Bushing(Top)
5. Body O-ring(Top)
6. Shaft Roller(Top)
7. Bushing(Bottom)
8. Body O-ring(Bottom)
9. Shaft Roller(Bottom)
10. Body Washer(Bottom)
11. Body Washer(Top)
12. Body Snap-ring
13. Piston
14. Piston O-ring

15. Piston Guide-ring
16. Piston Pin
17. Piston Roller
18. Piston Pad
19. Cover
20. Cover O-ring
21. Cover Bolt
22. Spring Cap
23. Spring
24. Stopper
25. Stopper Bolt
26. Stopper O-ring
27. Stopper Washer
28. Stopper Nut

AD SERIES (DOUBLE ACTING)

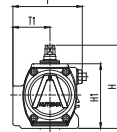
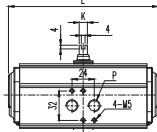
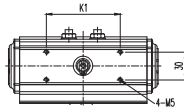

P	
AD50-AD200	PT 1/4"
AD250, AD300	PT 1/4" #PT 3/8" #PT 1/2"

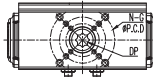
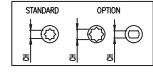

Dimension Table

MODEL	K1	ISO	ΦP.C.D	N-G	DP2(TAP)	K	L	T	T1	H	H1	CH	DP	Weight (Kg)
AD50	80	F03/F05/F07	36/50/70	4-M5/M6/M8	10/12/12.5	9	162	75	40	90	70	11x11	13	1.4
												#14x14	14	
AD65	80	F05/F07	50/70	4-M6/M8	14/14	13	202	89	46	107	87	14x14	17	2.3
												#11.7x017	14	
AD80	80	F07	70	4-M8	15	13	253	101	49.5	126	106	17x17	19	3.9
												#14.7x019	20	
AD100	80	F07/F10	70/102	4-M8/M10	16/21	19	311	129	61.5	148	128	22x22	26	6.7
AD125	80	F07/F10	70/102	4-M8/M10	16/19	19	390	151	71.5	174	154	22x22	26	11.3
												#17.7x022	26	
AD140	80	F10/F12	102/125	4-M10/M12	18/26	24	431	164	77	192	172	27x27	30	16.4
												#22x22	30	
AD160	80	F14	140	4-M16	27	24	506	188	89	216	196	36x36	30	23.7
		#F10/F12	#102/125	#4-M10/M12	18/25	24	506	188	89	216	196	#27x27	30	
AD185	80/130	F14	140	4-M16	26	30	578	217	102	254	224	36x36	30	34.8
												F16	165	
AD200	130	#F14	165	4-M20	30	36	605	231	115	284	254	#36x36	50	45.5
AD250	130	F16	165	4-M20	29	36	755	301	152	335	305	46x46	60	65.8
AD300	130	F16/F25	165/254	4-M20/8-M16	30/23	36	889	360	170	408	378	55x55	60	78.0

Option

Torque Table

Model	Angle	Supply Air					Model	Angle	Supply Air				
		4bar	4.5bar	5bar	6bar	7bar			4bar	4.5bar	5bar	6bar	7bar
AD50	0°	32.3	36.1	39.9	47.5	54.2	AD160	0°	1,187.5	1,330.0	1,472.5	1,748.0	2,033.0
	45°	20.0	22.8	24.7	29.5	34.2		45°	674.5	760.0	845.5	1,011.8	1,182.8
	90°	39.9	45.6	48.5	59.9	71.3		90°	1,363.3	1,581.8	1,805.0	2,123.3	2,503.3
AD65	0°	69.4	77.9	84.6	99.8	115.0	AD185	0°	1,520.0	1,719.5	1,900.0	2,251.5	2,584.0
	45°	43.7	49.4	55.1	65.6	76.0		45°	1,092.5	1,225.5	1,349.0	1,615.0	1,890.5
	90°	88.4	100.7	111.2	134.0	156.8		90°	1,919.0	2,175.5	2,441.5	3,021.0	3,581.5
AD80	0°	133.0	152.0	166.3	199.5	228.0	AD200	0°	2,612.5	2,888.0	3,163.5	3,676.5	4,218.0
	45°	76.0	85.5	95.0	114.0	137.8		45°	1,491.5	1,662.5	1,852.5	2,223.0	2,593.5
	90°	166.3	190.0	218.5	266.0	318.3		90°	2,432.0	2,755.0	3,068.5	3,705.0	4,322.5
AD100	0°	247.0	275.5	304.0	365.8	418.0	AD250	0°	4,275.0	4,750.0	5,272.5	6,222.5	7,125.0
	45°	147.3	166.3	185.3	223.3	266.0		45°	2,498.5	2,812.0	3,097.0	3,743.0	4,389.0
	90°	266.0	304.0	342.0	418.0	494.0		90°	4,617.0	5,177.5	5,776.0	6,944.5	8,189.0
AD125	0°	508.3	574.8	631.8	745.8	855.0	AD300	0°	6,732.0	8,416.0	10,099.0	11,193.1	12,118.8
	45°	323.0	361.0	399.0	475.0	555.8		45°	3,960.0	4,950.0	5,940.0	6,983.5	7,128.0
	90°	612.8	698.3	821.8	983.3	1,144.8		90°	9,415.0	12,019.0	14,422.0	15,984.4	17,306.4
AD140	0°	779.0	874.0	969.0	1,159.0	1,339.5							
	45°	427.5	479.8	532.0	641.3	750.5							
	90°	788.5	893.0	1,007.0	1,263.5	1,539.0							

(Nm)

AS SERIES (SINGLE ACTING)

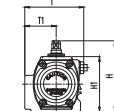
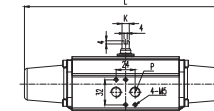
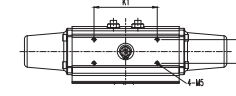

P	
AS50-AS200	PT 1/4"
AS250, AS300	PT 1/4" #PT 3/8" #PT 1/2"

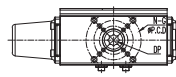
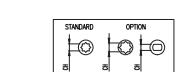

Dimension Table

MODEL	K1	ISO	ΦP.C.D	N-G	DP2(TAP)	K	L	T	T1	H	H1	CH	DP	Weight (Kg)
AS50	80	F03/F05/F07	36/50/70	4-M5/M6/M8	10/12/12.5	9	257	75	40	90	70	11x11	13	1.6
												#14x14	14	
AS65	80	F05/F07	50/70	4-M6/M8	14/14	13	314	89	46	107	87	14x14	17	3.0
												#11.7x017	14	
AS80	80	F07	70	4-M8	15	13	421	101	49.5	126	106	17x17	19	5.3
												#14.7x019	20	
AS100	80	F07/F10	70/102	4-M8/M10	16/21	19	500	129	61.5	148	128	22x22	26	9.5
AS125	80	F07/F10	70/102	4-M8/M10	16/19	19	606	151	71.5	174	154	22x22	26	17.6
												#17.7x022	26	
AS140	80	F10/F12	102/125	4-M10/M12	18/26	24	682	164	77	192	172	27x27	30	23.9
												#22x22	30	
AS160	80	F14	140	4-M16	27	24	781	188	89	216	196	36x36	30	36.6
		#F10/F12	#102/125	#4-M10/M12	18/25	24	781	188	89	216	196	#27x27	30	
AS185	80/130	F14	140	4-M16	26	30	894	217	102	254	224	36x36	30	56.9
												F16	165	
AS200	130	#F14	165	4-M20	30	36	982	231	115	284	254	#36x36	50	77.2
AS250	130	F16	165	4-M20	29	36	1108	301	152	335	305	46x46	60	119.6
AS300	130	F16/F25	165/254	4-M20/8-M16	30/23	36	1345	372	170	408	378	55x55	60	145.0

Option

Torque Table

Model	Angle	Spring Torque Middle		Spring Torque Strong		Model	Angle	Spring Torque Middle		Spring Torque Strong	
		Spring	AIR to 4.5bar	Spring	AIR to 6bar			Spring	AIR to 4.5bar	Spring	AIR to 6bar
AS50	0°	16.2	22.8	23.0	28.3	AS160	0°	503.5	902.5	888.3	1,059.3
	45°	12.0	10.8	16.5	14.3		45°	289.8	465.5	498.8	508.3
	90°	24.2	11.4	33.3	14.0		90°	536.8	789.5	940.5	731.5
AS65	0°	43.7	49.4	56.6	64.9	AS185	0°	1,035.5	1,111.5	1,548.5	1,292.0
	45°	24.9	23.3	34.4	32.3		45°	579.5	598.5	874.0	703.0
	90°	47.2	30.6	65.2	39.9		90°	1,140.0	855.0	1,681.5	931.0
AS80	0°	76.0	95.0	114.0	123.5	AS200	0°	1,206.5	1,833.5	1,681.5	2,375.0
	45°	42.8	42.8	61.8	61.8		45°	674.5	921.5	1,035.5	1,092.5
	90°	85.5	61.8	118.8	85.5		90°	1,239.8	1,349.0	1,947.5	1,472.5
AS100	0°	114.0	166.3	152.0	237.5	AS250	0°	2,213.5	3,097.0	3,277.5	3,942.5
	45°	76.0	76.0	99.8	118.8		45°	1,254.0	1,605.5	1,738.5	2,071.0
	90°	152.0	99.8	209.0	152.0		90°	2,432.0	2,318.0	3,315.5	2,888.0
AS125	0°	285.0	384.8	408.5	470.3	AS300	0°	6,421.0	4,308.0	8,566.0	5,740.0
	45°	166.3	204.3	237.5	247.0		45°	2,283.0	2,172.0	3,046.0	2,894.0
	90°	318.3	318.3	446.5	384.8		90°	3,266.0	4,396.0	4,359.0	5,857.0
AS140	0°	384.8	555.8	574.8	693.5						
	45°	228.0	247.0	332.5	318.3						
	90°	446.5	375.3	617.5	465.5						

(Nm)

TECHNICAL DATA

Scotch-Yoke Type

- Upon air supply, pistons move horizontally, turning the shaft by the arm connected to the pistons.
- Smooth On/Off with the torque curve synchronized with valves.
- Relatively higher torque than the same model in Rack&Pinion Type.

Torque Diagram

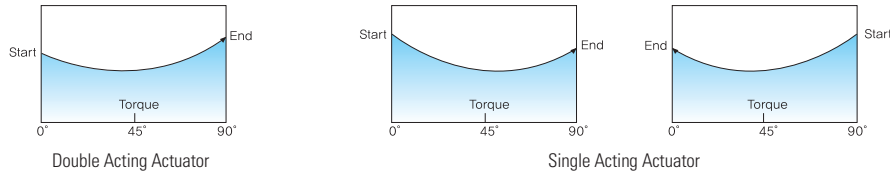

Air Consumption

- The air consumption of actuator is calculated by below.
- The air consumption is based on 1 action of used valve and do calculate the consumption per an hour.

Double Acting Actuator (AD Series)	V = Air Consumption (Liter) A = Volume "A" (Liter) B = Volume "B" (Liter) P = Supply Air Pressure (Bar) N = Number of Operating
$V = (A+B)(P+1.013) \times N$	
Single Acting Actuator (AS Series)	
$V = A \times (P+1.013) \times N$	

Operating Mechanism

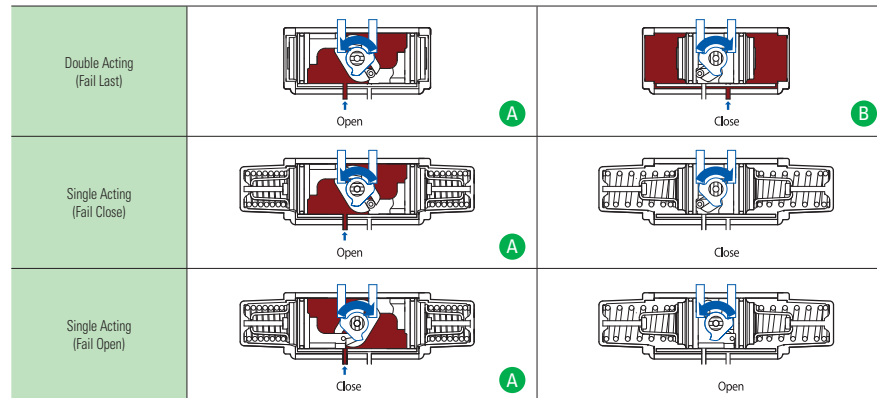

Double Acting			Single Acting		
Model	A	B	Model	A (Fail Close)	A (Fail Open)
AD50	0.2	0.2	AS50	0.2	0.2
AD65	0.3	0.3	AS65	0.3	0.3
AD80	0.6	0.5	AS80	0.6	0.5
AD100	1.2	1.1	AS100	1.2	1.0
AD125	2.5	2.2	AS125	2.5	2.1
AD140	3.9	3.5	AS140	3.9	3.3
AD160	4.8	4.3	AS160	4.8	4.0
AD185	5.8	7.5	AS185	5.8	6.1
AD200	6.2	9.9	AS200	6.2	7.6
AD250	8.0	12.8	AS250	8.0	9.9

RACK&PINION TYPE ACTUATOR

Features

- Aluminum Cover Which is not easily peeled off, and its polish can last long as it is power coated upon special surface treatment.
- Spring Cap Which can enable it to assemble or disassemble safely.
- NBR The products can be used at **Low/High temperature** as the products are available in EPDM and/or VITON in addition to the standard NBR.
- ISO5211/DIN3337 Which is the international standards and thus it can precisely be fitted with accessories such as limit switch box and so on.
- Aluminum Body **anodized** to prevent internal/external scratches and thus securing long term durability.
- NAMUR Which is the international standards and thus the products can be precisely fitted with solenoid valves.

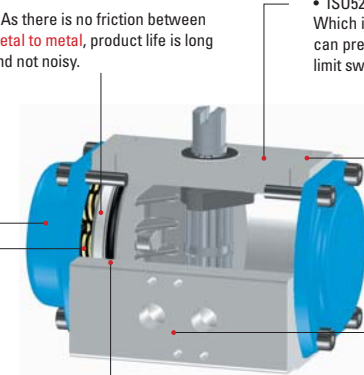

Part List

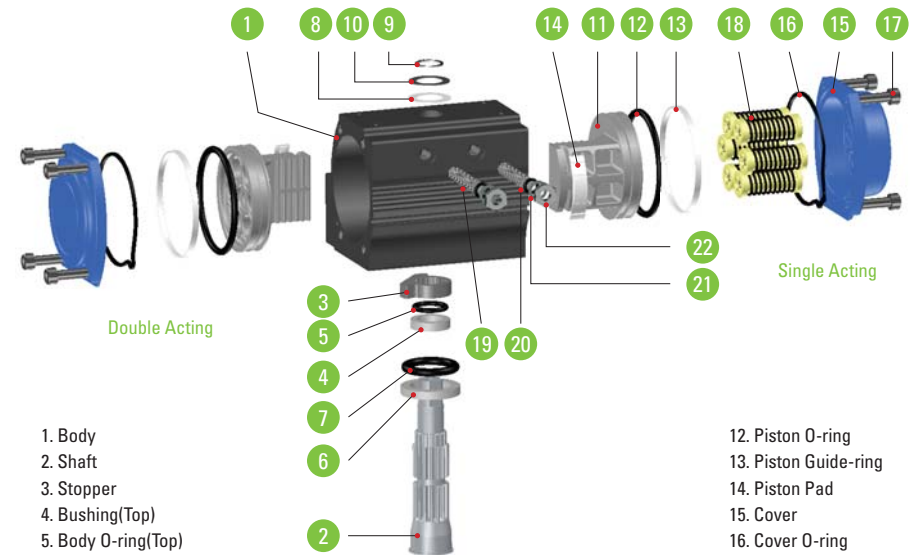

1. Body
2. Shaft
3. Stopper
4. Bushing(Top)
5. Body O-ring(Top)
6. Bushing(Bottom)
7. Body O-ring(Bottom)
8. Body Washer(Bottom)
9. Body Washer(Top)
10. Body Snap-ring
11. Piston
12. Piston O-ring
13. Piston Guide-ring
14. Piston Pad
15. Cover
16. Cover O-ring
17. Cover Bolt
18. Spring Unit
19. Stopper Bolt
20. Stopper O-ring
21. Stopper Washer
22. Stopper Nut

ADR/ASR SERIES (DOUBLE ACTING/SINGLE ACTING)

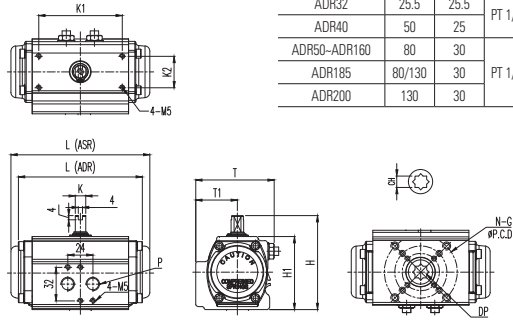

	K1	K2	P
ADR32	25.5	25.5	PT 1/8"
ADR40	50	25	
ADR50-ADR160	80	30	
ADR185	80/130	30	PT 1/4"
ADR200	130	30	

Dimension Table

MODEL	ISO	ØP.C.D	N-G	DP2(TAP)	K	L		T	T1	H	H1	CH	DP	Weight (Kg)	
						ADR	ASR							ADR	ASR
ADR32	F03	36	4-M5	7	7	66	-	45	25	55	45	9-9	9	0.3	-
ADR40	F03/F05	36/50	4-M5/M6	8/12	9	97	97	63	32	75	55	9-9	9	0.5	0.6
ADR50	F03/F05/F07	36/50/70	4-M5/M6/M8	10/12/12.5	9	119	133	75	40	90	70	11x11	13	1.0	1.1
ADR65	F05/F07	50/70	4-M6/M8	11/11	13	131	154	89	46	106.5	85.5	14x14	16	1.4	1.5
ADR80	F07	70	4-M8	15	19	189	220	101	49.5	126	106	17x17	19	2.9	3.3
ADR90	F07	70	4-M8	17	19	188	223	104	54.5	136	116	17x17	19	3.4	3.8
ADR100	F07/F10	70/102	4-M8/M10	16/21	19	229	256	132	61.5	148	128	22x22 #17x17	26	4.7	5.4
ADR115	F07/F10	70/102	4-M8/M10	16/19	19	265	302	142	67.5	163	143	22x22	26	6.7	7.5
ADR125	F07/F10	70/102	4-M8/M10	16/19	19	299	330	151	71.5	174	154	22x22	26	8.6	9.9
ADR140	F10/F12	102/125	4-M10/M12	18/26	24	332	389	164	77	192	172	27x27 #22x22	30	12.4	14.5
ADR160	F10/F12	102/125	4-M10/M12	18/25	24	364	416	188	89	216	196	27x27	30	16.9	19.5
ADR185	F14	140	4-M16	23	30	434	465	217	103	254	224	36x36	30	24.2	29.0
ADR200	F14	140	4-M16	23	36	444	527	231	115	284	254	36x36	30	32.3	37.9

* ADR32, 40 Have not angle stopper.

Option

Torque Table - ADR Series

Model	Supply Air					
	3bar	4bar	4.5bar	5bar	6bar	7bar
ADR32	2.4	3.1	3.5	3.9	4.8	5.7
ADR40	5.5	7.4	8.4	9.2	11.1	13.0
ADR50	9.4	12.5	14.3	15.9	19.1	22.5
ADR65	18.3	24.7	27.8	30.8	36.8	42.9
ADR80	44.5	58.9	66.5	74.4	89.3	104.3
ADR90	57.2	76.2	85.7	95.2	114.2	133.2
ADR100	79.5	105.5	118.8	132.1	158.7	185.3
ADR115	123.5	166.3	187.2	209.0	251.8	294.5
ADR125	161.5	218.5	247.0	270.8	327.8	384.8
ADR140	237.5	318.3	361.0	399.0	479.8	560.5
ADR160	327.8	441.8	494.0	551.0	669.8	779.0
ADR185	475.0	641.3	722.0	802.8	964.3	1,125.8
ADR200	679.3	912.0	1,030.8	1,144.8	1,382.3	1,615.0

ASR SERIES (SINGLE ACTING)

Torque Table - ASR Series

Model	Spring Unit	Supply Air												Spring	
		3bar		4bar		4.5bar		5bar		6bar		7bar			
		0°	90°	0°	90°	0°	90°	0°	90°	0°	90°	0°	90°		
ASR40	S	1.0	-	2.9	0.5	3.8	1.2	4.8	2.1	6.7	3.8	8.6	5.1	3.9	5.9
	MS	1.9	-	3.7	1.0	4.6	1.8	5.4	2.5	7.3	4.2	9.1	5.6	3.0	4.9
	M	2.6	0.8	4.6	2.4	5.4	3.2	6.3	4.1	8.1	5.9	10.0	7.7	2.8	4.1
	WS	2.7	0.7	4.6	1.7	5.4	2.3	6.4	2.9	8.2	4.1	10.1	5.2	2.1	3.0
	WM	3.2	1.5	5.0	3.1	5.0	3.8	6.0	4.6	6.9	5.9	8.8	7.1	1.6	2.4
ASR50	8	4.1	1.2	7.4	4.4	9.0	6.1	10.7	7.6	14.2	11.1	17.3	14.5	5.2	8.1
	9	3.6	-	6.9	3.4	8.6	5.2	10.3	6.9	13.6	10.2	16.9	13.6	6.0	9.1
	10	2.9	-	6.1	2.7	7.8	4.3	9.5	5.9	12.8	9.3	16.2	12.6	6.5	10.1
	11	2.3	-	5.6	1.5	7.3	3.1	8.9	4.8	12.4	8.2	15.7	11.5	7.0	11.0
ASR65	8	4.1	1.2	8.7	3.6	14.7	9.5	17.9	12.5	21.1	15.7	27.2	22.0	8.4	13.7
	9	3.6	-	7.6	1.3	14.0	7.5	17.1	10.7	20.0	13.8	26.3	20.0	9.7	15.2
	10	2.9	-	6.1	-	12.3	5.3	15.4	8.6	18.5	11.8	24.7	18.1	11.0	17.4
ASR80	8	4.1	1.2	8.7	3.6	14.7	9.5	17.9	12.5	21.1	15.7	27.2	22.0	8.4	13.7
	9	3.6	-	7.6	1.3	14.0	7.5	17.1	10.7	20.0	13.8	26.3	20.0	9.7	15.2
	10	2.9	-	6.1	-	12.3	5.3	15.4	8.6	18.5	11.8	24.7	18.1	11.0	17.4
ASR90	8	21.1	6.1	35.3	21.0	42.9	29.1	50.5	35.7	65.6	51.3	80.8	66.4	21.7	33.7
	9	17.6	-	32.4	15.7	39.9	23.8	47.4	30.4	62.4	45.3	77.7	60.1	24.8	38.3
	10	14.3	-	29.5	11.0	37.1	19.0	44.3	25.7	59.8	40.4	74.5	55.5	28.2	43.7
	11	11.4	-	26.2	5.7	33.4	12.9	40.5	20.4	56.1	35.3	70.8	49.9	30.3	47.7
ASR100	8	27.7	6.7	47.3	25.7	56.6	35.2	65.8	44.7	85.1	63.7	104.1	82.7	27.2	43.9
	9	23.1	-	42.5	18.8	51.6	28.9	61.4	38.0	80.8	57.4	100.0	77.0	30.7	49.8
	10	19.2	-	38.0	12.7	47.5	21.9	57.0	31.4	76.0	50.8	95.0	69.8	34.5	56.5
ASR115	8	34.9	4.8	60.8	29.6	74.1	43.7	86.7	56.1	113.1	81.9	139.7	108.3	40.9	67.6
	9	30.6	-	57.0	20.9	70.3	33.7	83.1	46.6	109.3	74.1	135.9	100.2	45.6	76.4
	10	25.2	-	52.7	11.8	66.9	24.1	79.3	36.9	105.5	64.1	132.1	90.0	50.4	87.2
ASR125	8	61.8	23.8	104.5	66.5	128.3	85.5	147.3	103.3	190.0	152.0	232.8	190.0	52.3	85.5
	9	52.3	9.5	95.5	52.3	118.8	71.3	137.8	95.0	185.3	142.5	228.0	180.5	61.8	98.8
	10	42.8	-	85.5	42.8	109.3	61.8	128.3	80.8	175.8	123.5	218.5	166.3	66.5	114.0
ASR140	8	76.0	28.5	128.3	80.8	156.8	109.3	180.5	137.8	237.5	194.8	289.8	247.0	71.3	114.0
	9	66.5	9.5	118.8	66.5	147.3	95.0	175.8	123.5	228.0	175.8	280.3	232.8	85.5	133.0
	10	52.3	-	109.3	47.5	137.8	76.0	161.5	104.5	218.5	161.5	270.8	213.8	95.0	147.3
	11	42.8	-	99.8	33.3	128.3	61.8	152.0	85.5	209.0	142.5	261.3	199.5	104.5	161.5
ASR160	8	114.0	42.8	194.8	123.5	237.5	166.3	275.5	204.3	356.3	289.8	437.0	370.5	104.5	175.8
	9	95.0	14.3	175.8	99.8	218.5	142.5	256.5	180.5	337.3	266.0	418.0	346.8	118.8	194.8
	10	85.5	-	166.3	76.0	204.3	118.8	242.3	156.8	323.0	242.3	408.5	323.0	137.8	218.5
ASR185	8	147.3	52.3	261.3	166.3	318.3	218.5	375.3	289.8	498.3	394.3	603.3	508.3	161.5	242.3
	9	123.5	14.3	242.3	128.3	299.3	185.3	356.3	242.3	470.3	356.3	584.3	470.3	185.3	275.5
	10	104.5	-	218.5	99.8	270.8	152.0	327.8	209.0	446.5	323.0	560.5	437.0	204.3	313.5
ASR200	8	204.3	66.5	365.8	228.0	446.5	304.0	532.0	384.8	693.5	546.3	850.3	703.0	251.8	370.5
	9	171.0	9.5	337.3	171.0	418.0	251.8	494.0	332.5	660.3	494.0	821.8	660.3	285.0	422.8
	10	137.8	-	304.0	118.8	384.8	199.5	460.8	280.3	627.0	446.5	788.5	608.0	318.3	465.5
ASR200	8	332.5	152.0	570.0	380.0	684.0	498.8	802.8	617.5	1,035.5	850.3	1,263.5	1,078.3	327.8	489.3
	9	285.0	76.0	517.8	313.5	636.5	432.3	750.5	546.3	988.0	779.0	1,216.0	1,016.5	375.3	555.8
	10	232.8	9.5	465.5	242.3	584.3	356.3	703.0	475.0	935.8	712.5	1,168.5	945.3	427.5	622.3
ASR200	11	185.3	-	422.8	175.8	532.0	294.5	655.5	408.5	888.3	646.0	1,121.0	878.8	465.5	684.0
	12	147.3	-	384.8	114.0	498.8	237.5	612.8	342.0	850.3	574.8	1,083.0	812.3	503.5	745.8

(Nm)

TECHNICAL DATA

Rack & Pinion Type

- Upon air supply, pistons move horizontally, turning the shaft that is linked to the piston gear.
- Short body length makes it easier to fit in small spaces.
- The multi-spring structure enables adjustment of number of springs to suit the site requirements.

Torque Diagram

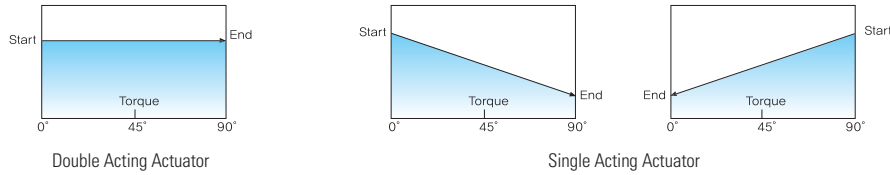

Air Consumption

- The air consumption of actuator is calculated by below.
- The air consumption is based on 1 action of used valve and do calculate the consumption per an hour.

Double Acting Actuator (ADR Series)	$V = (A+B) \times (P+1.013) \times N$	V = Air Consumption (Liter) A = Volume "A" (Liter) B = Volume "B" (Liter) P = Supply Air Pressure (Bar) N = Number of Operating
Single Acting Actuator (ASR Series)	$V = A \times (P+1.013) \times N$	

Operating mechanism

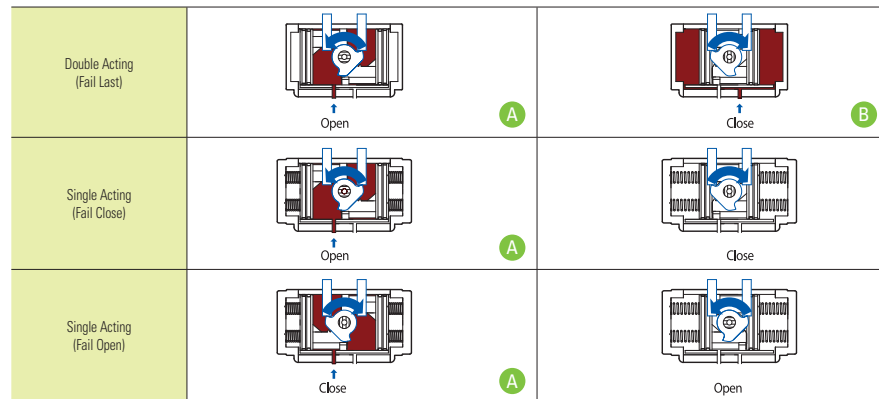

Double Acting			Single Acting		
Model	A	B	Model	A (Fail Close)	A (Fail Open)
ADR32	0.1	0.1			
ADR40	0.1	0.1	ASR40	0.1	0.1
ADR50	0.2	0.1	ASR50	0.2	0.1
ADR65	0.3	0.2	ASR65	0.3	0.2
ADR80	0.4	0.4	ASR80	0.4	0.4
ADR90	0.7	0.6	ASR90	0.7	0.6
ADR100	0.9	0.9	ASR100	0.9	0.8
ADR125	2.0	1.8	ASR125	2.0	1.7
ADR140	3.2	2.8	ASR140	3.2	2.7
ADR160	3.8	3.5	ASR160	3.8	3.3
ADR210	12.5	11.3	ASR210	12.5	10.6

HEAVY-DUTY ACTUATOR

Double Acting

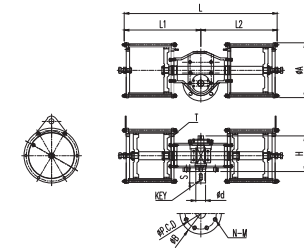

Dimension Table

MODEL	ØA	L	L1	L2	H	T	S	KEY	Ød	P.C.D	ØB	N-M
AD250D	313	900	450	450	202	PT 3/8"	65	16x10T	55	165	200	4-M20
AD300D	370	1100	550	550	240	PT 3/8"	85	20x14T	70	254	300	8-M16
AD350D	410	1400	700	700	302	PT 1/2"	85	28x16T	80	298	340	8-M20
AD400D	470	1600	800	800	308	PT 1/2"	85	28x16T	80	298	340	8-M20

Single Acting

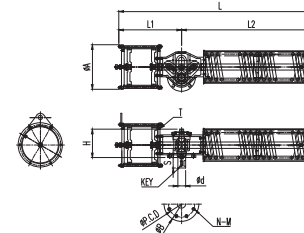

Dimension Table

MODEL	ØA	L	L1	L2	H	T	S	KEY	Ød	P.C.D	ØB	N-M
AS250D	313	1450	450	1000	202	PT 3/8"	65	16x10T	55	165	200	4-M20
AS300D	370	1650	550	1100	240	PT 3/8"	85	20x14T	70	254	300	8-M16
AS350D	410	1860	700	1160	302	PT 1/2"	85	28x16T	80	298	340	8-M20

Torque Table

Model	Angle	Supply Air			Model	Angle	Supply Air			
		4bar	5bar	6bar			4bar	5bar	6bar	Spring
AD250D	0°	4,200	5,200	6,300	AS250D	0°	1,170	1,810	2,350	1,300
	45°	3,100	3,800	4,600		45°	590	950	1,340	840
	90°	4,200	5,200	6,300		90°	930	1,800	1,980	1,470
AD300D	0°	11,740	15,000	18,300	AS300D	0°	2,400	3,650	4,800	2,550
	45°	5,600	7,000	8,400		45°	1,180	1,850	2,500	1,500
	90°	10,100	12,400	14,800		90°	1,760	3,160	4,600	3,130
AD350D	0°	16,000	21,600	28,600	AS350D	0°	4,650	6,800	8,900	3,650
	45°	9,600	11,600	13,700		45°	1,450	2,600	3,700	2,730
	90°	14,000	17,800	20,500		90°	1,330	3,200	5,250	5,200
AD400D	0°	21,600	29,100	38,600						
	45°	12,950	15,650	18,500						
	90°	18,900	24,000	27,650						

Air Consumption

Model	A	B	Model	A (Fail Close)	A (Fail Open)
AD250D	120	120	AS250D	60	58
AD300D	215	215	AS300D	107	104
AD350D	360	360	AS350D	185	180
AD400D	544	544			

Weight

Model (Double)	Model (Single)
AD250D	AS250D
AD300D	AS300D
AD350D	AS350D
AD400D	