

**HIGH PERFORMANCE BUTTERFLY VALVE ANSI-150LB**  
 AT311 - SCS13/CF8 BODY      AT411 - WCB BODY  
 AT511 - FCD450 BODY      AT622 - SCS14/CF8M BODY

**AT411 - WCB-body CF8-disc MTFE-seat**

**AT622 - CF8M-body CF8M-disc INCONEL-seat**

**Lever type/레바식**

**Gear type/기어식**

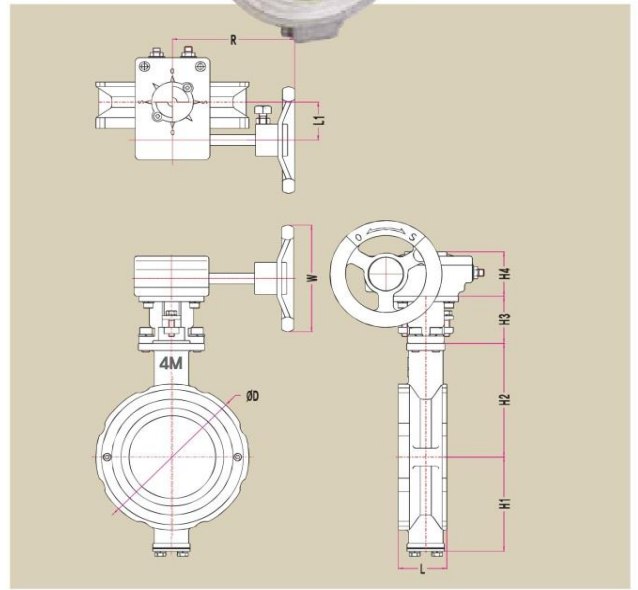
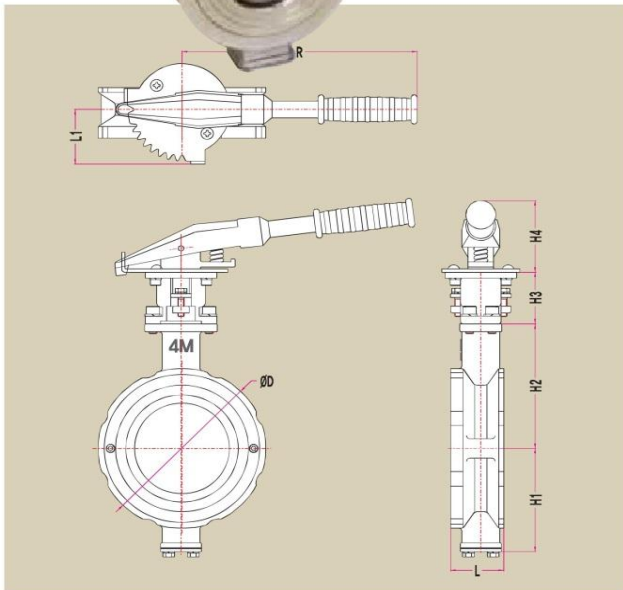

**Lever Type**

Size	mm	L	Ø D	H1	H2	H3	H4	R
1-1/2	40	43	86	73	91	53	74	212
2	50	44	100	81	98	53	74	212
2-1/2	65	46	120	83	109	53	74	212
3	80	46	132	87	113	53	76	228
4	100	52	164	111	129	53	76	228

**Gear Type**

Size	mm	L	Ø D	H1	H2	H3	H4	H5	R	L1	Ø W
1-1/2	40	43	86	73	91	53	25	20	160	43	120
2	50	44	100	81	98	53	25	20	160	43	120
2-1/2	65	46	120	83	109	53	25	20	160	43	120
3	80	46	132	87	113	53	25	20	160	43	120
4	100	52	164	111	129	53	25	20	160	43	120
5	125	57	194	121	152	53	35	40	220	73	180
6	150	62	225	145	173	53	35	40	220	73	180
8	200	64	277	180	227	53	35	40	280	73	240
10	250	72	337	220	265	53	35	40	280	73	240

# 이중편심 고성능 버터플라이 밸브

## Water type high performance butterfly valve

4M 고성능 버터플라이 밸브는 다목적으로 사용이 가능하며

최대사용압력 : 20kgf/cm<sup>2</sup>

최대사용온도 : RTFE Seat-200°C, Metal Seat-240°C이상~600°C

의 환경에 적용이 가능한 밸브입니다. (적용환경에 따라 주문제작이 가능)

밸브의 내구성을 높이기 위해 이중편심구조로 제작이 되며  
 4M 독자적인 시트구조로 시트마모를 최소화하여  
 밸브수명을 연장하였습니다.

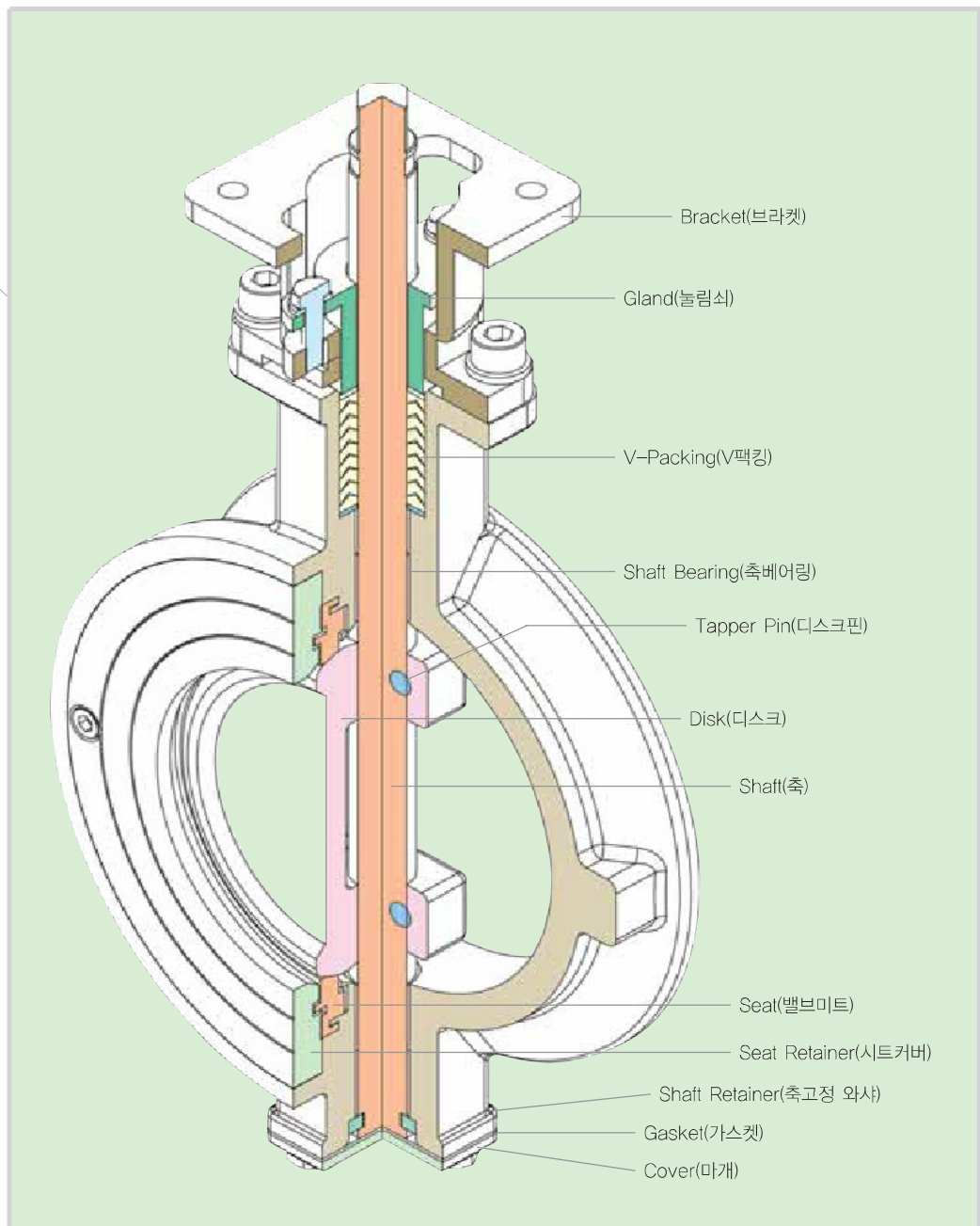

# AUTOMA HIGH PERFORMANCE BUTTERFLY VALVES

## HIGH PERFORMANCE BUTTERFLY VALVE ANSI-150LB SERIES SC14/CF8M BODY SERIES 622/SUS316 BODY

### AT511 - FCD450 BODY AT622 - SCS14/CF8M BODY

## Features

### ▽ 디스크의 이중편심구조

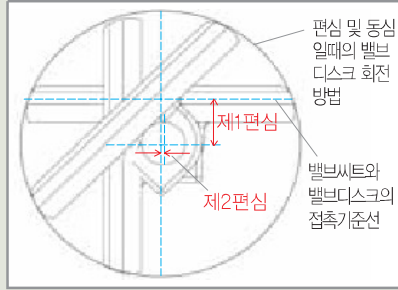

밸브씨트와 밸브디스크의 접촉기준선과 밸브디스크의 회전축이 2중으로 편심을 주어 밸브가 개폐되면서 밸브씨트와 밸브디스크가 분리되도록 설계되었습니다. (밸브수명연장, 밸브토오크감소)

### ▽ 메탈씨트 구조

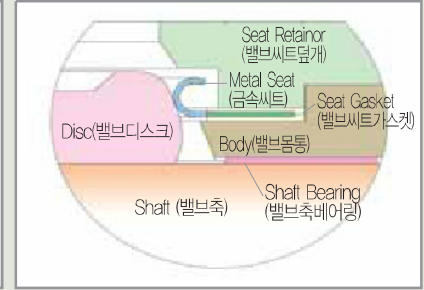

240°C이상의 고온유체나 슬러지를 포함한 유체에 적용할 수 있도록 밸브씨트를 금속재질을 사용하여 적용하였습니다.

### ▽ 견고한 고정

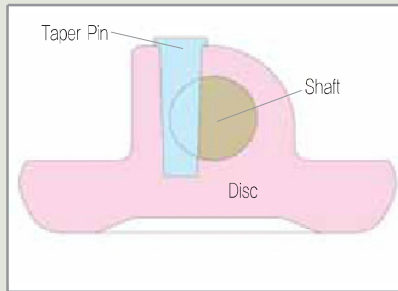

디스크핀이 견고하게 고정되어 있습니다. 평행핀에 비해 고정되는 힘이 강한 테이퍼핀을 사용하였으며 핀이 밸브 축의 1/3지점에 위치하여 핀의 전단응력을 보완하여 내구성을 향상시켰습니다.

### ▽ 유지보수 용이

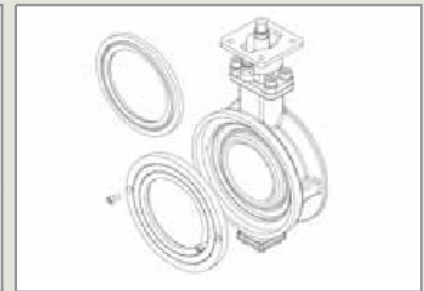

유지보수가 편리합니다. 현장에서 밸브씨트 교체가 가능하여 보수가 편리합니다.

## 표준사양 / Standard Spec. I

밸브형식 / Valve Type		RTFE seated Type	Metal seated Type
공칭규격 / SIZE		40, 50, 65, 80, 100, 125, 150, 200, 250, 300, 350, 400, 450, 500, 550, 600, 650, 700, 750, 800, 850, 900, 1000	
면간거리 / Face-to-Face		Maker Standard (ISO 5752 or API 609)	
배관형식 / Configuration		웨이퍼 타입 / Wafer Type	
적용 플랜지 규격 / Applicable Flange Standard		KS 10K, 16K, 20K / JIS 10k, 16K, 20K ANSI 150Lb / DIN 10K, 16K	
표준재질 Standard Material	바디 / Body	FCD 450 or SSC 13	
	디스크 / Disc	SSC 13	SSC 13 (Cr.Plated/경질도금)
	씨트 / Seat	PTFE or RTEE (몰리브덴)	SUS 304 or 316, Inconel
	축 / Shaft	SUS 304	
	축용 팩킹 / Gland Packing	PTFE or RTEE (With Carbon/카본)	
기타 팩킹 / Other Packing		Non-Asbestos / 비석면, 스팀용 가스켓	
최대사용압력 / Max. Working Pressure		20kgf/cm <sup>2</sup> 10kgf/cm <sup>2</sup> for 650mm or more	10kgf/cm <sup>2</sup>
최대사용온도 / Max. Working Temperature		-20°C ~ 200°C	
적용유체 / Fluid Application		공기, 온수, 증기, 유류, 불활성 가스, 화학약품 등 Dry Air, Hot Water, Steam, Oil, Exhaust Gas, Chemical Products etc.	
시험압력 Test Pressure	몸통내압 / Body	32kgf/cm <sup>2</sup>	32kgf/cm <sup>2</sup>
	씨트누설 / Seat	24kgf/cm <sup>2</sup> (12kgf/cm <sup>2</sup> for 650mm or more)	12kgf/cm <sup>2</sup>

## ■ Standard Production Range

Rating		JIS		ANSI
		10K	20K	Class 150
Size	inch	1 1/2"~40"	1 1/2"~28"	1 1/2"~24"
	mm	40~1000	40~700	40~600
Connection		Wafer type		
Actuator	Manual	Lock lever handle, Worm gear		
	Automatic	Pneumatic double act, Pneumatic single Act(spring-return), Electric Act		

## ■ Main Materials

Rating	JIS		ANSI
	10K	20K	Class 150
Body	Ductile iron(FCD45) Stainless steel(SCS13, CF8, SCS14, CF8M) Carbon steel(SCPH2, WCB)		
Disc	Stainless steel(SCS13, CF8, SCS14, CF8M)		
Stem	SUS304, SUS316		
Seat	PTFE, RTFE, SUS304, SUS316, etc.		
Glandpacking	PTFE, RTFE, graphite		

## ■ Seat Material and Working Temperature

Seat Materials	Maximum Working Temperature °C(°F)
PTFE	160(320)
RTFE	180(356)
MTEF	195(383)

## ■ Working Pressure and Test Pressure

### Working Pressure

Body	20kgf/cm <sup>2</sup>	19.6MPa
Seat	20kgf/cm <sup>2</sup>	19.6MPa

### Test Pressure

Body	32kgf/cm <sup>2</sup>	31.36MPa
Seat	24kgf/cm <sup>2</sup>	23.52MPa

## ■ 4M Applications

- Oil refining
- Sugar refining
- Food processing
- Chemical machinery industries
- Vaccum
- Marine tankers(shipbuilding)and offshore plant construction
- Chemical and petrochemical processing
- Coal and mining industries
- On/Off control
- Power generating plants
- Flow control
- Pulp and paper manufacturing
- Gas and steam line installation
- Textile machinery
- Desalination
- Slurry

## ■ Seat Ratings

**ANSI Class 150**

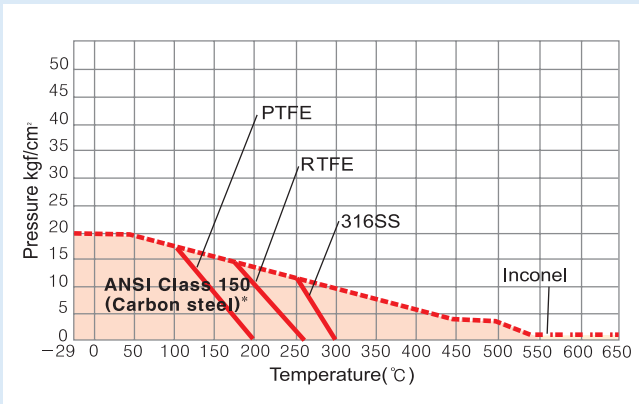

**ANSI Class 300**

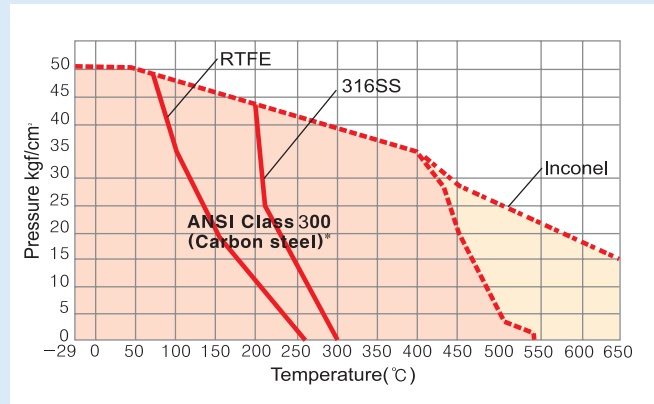

### Notes to SEAT RATINGS ANSI Class 150

Valve sizes larger than 14(350mm) equipped with 304SS or 316SS shafts are rated for maximum differential press of 150 psi(10kgf/cm<sup>2</sup>).

### ANSI Class 300

Maximum differential pressure for valves equipped with 304SS or 316SS shafts is 300 psi(21kgf/cm<sup>2</sup>).

\*Body rating is based on carbon steel.

## ■ Valve Body Ratings

These are maximum working pressures for bodies only.

The seat ratings shown above determine the practical pressure limitations.

ANSI B16.34(1988)

ANSI Class Temperature °C (°F)	150		300	
	Carbon steel MPa(psi)	316SS MPa(psi)	Carbon steel MPa(psi)	316SS MPa(psi)
-29(-20)to38(100)	2.0(285)	1.9(275)	5.2(740)	5.0(720)
100(200)	1.8(260)	1.7(240)	4.7(675)	4.3(620)
150(300)	1.6(230)	1.5(215)	4.6(655)	3.9(560)
200(400)	1.4(205)	1.4(205)	4.4(635)	3.6(515)
260(500)	1.2(170)	1.2(170)	4.2(600)	3.3(480)
320(600)	1.0(140)	1.0(140)	3.9(560)	3.2(450)
340(650)	0.87(125)	0.87(125)	3.7(535)	3.1(445)
370(700)	0.77(110)	0.77(110)	3.7(535)	3.0(430)
400(750)	0.66(95)	0.66(95)	3.5(505)	3.0(430)
430(800)	0.56(80)	0.56(80)	2.9(415)	2.9(415)
450(850)	0.46(65)	0.46(65)	1.9(275)	2.8(405)
480(900)	0.35(50)	0.35(50)	1.2(170)	2.8(395)
510(950)	0.25(35)	0.25(35)	0.74(150)	2.7(385)
540(1000)	0.14(20)	0.14(20)	0.35(50)	2.6(365)
570(1050)	-	-	-	2.5(360)
590(1100)	-	-	-	2.3(325)
620(1150)	-	-	-	1.9(275)
650(1200)	-	-	-	1.4(205)
Test pressure	3.1(445)	2.9(415)	7.9(1125)	7.7(1100)

## ■ Allowable Seat Leakage

### Soft Seat

Leakage of the soft-seated versions(PTFE, RTFE seated) is ZERO

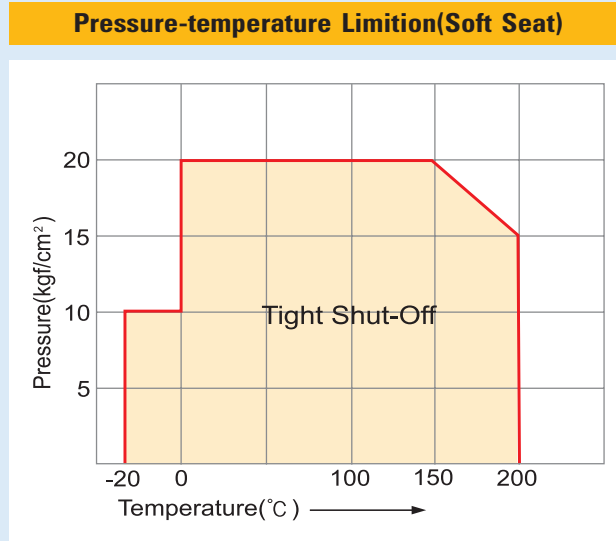

### Metal Seat(Class V)

Leakage of metal-seats is in accordance with Class V(Water) of ANSI/FCI 70.2(1976)for allowable seat leakage.

Unit : cc/minute

Size		$\Delta P$ (bar)			
inch	mm	10	16	20	25
2	50	0.15	0.24	0.30	0.38
2-1/2	65	0.19	0.30	0.38	0.48
3	80	0.24	0.38	0.48	0.60
4	100	0.30	0.48	0.60	0.75
5	125	0.38	0.60	0.75	0.95
6	150	0.45	0.72	0.90	1.13
8	200	0.60	0.96	1.20	1.50
10	250	0.75	1.20	1.50	1.88
12	300	0.90	1.44	1.80	2.25
14	350	1.05	1.68	2.10	2.63
16	400	1.20	1.92	2.40	3.00
18	450	1.35	2.16	2.70	3.38
20	500	1.50	2.40	3.00	3.75
22	550	1.65	2.64	3.30	4.13
24	600	1.80	2.88	3.60	4.50

$Q_a$ (allowable leakage)(cc/minute)= $3 \times 10 \times$  nominal size(mm) $\times \Delta P$ (bar) or  $0.0075 \times$  nominal size(inch) $\times \Delta P$ (bar)

$\Delta P$ =max. differential pressure

# ■ Cv-value

## ANSI Class 150/300

Size		Class	Degree of disc rotation(°)								
inch	mm		10	20	30	40	50	60	70	80	90
2	50	150~300	2	7	13	21	31	46	64	84	92
2-1/2	65	150~300	4	12	21	35	51	75	105	137	150
3	80	150~300	6	20	36	60	88	132	182	238	260
4	100	150~300	14	36	64	106	162	235	326	414	460
5	125	150~300	22	60	105	175	260	390	540	670	760
6	150	150	40	100	165	265	400	600	805	1025	1150
		300	30	76	125	200	305	460	615	785	880
8	200	150	65	170	290	485	735	1080	1490	1850	2100
		300	60	155	265	440	665	980	1350	1675	1900
10	250	150	100	260	445	735	1120	1680	2270	2850	3200
		300	90	230	390	645	980	1470	1985	2495	2800
12	300	150	150	385	660	1080	1645	2520	3385	4185	4700
		300	130	335	575	945	1435	2200	2955	3650	4100
14	350	150	190	470	810	1335	1950	2850	4060	5105	5800
		300	180	445	770	1265	1850	2705	3850	4840	5500
16	400	150	250	650	1110	1820	2720	3900	5670	7100	8000
		300	235	615	1055	1730	2585	3705	5385	6745	7600
18	450	150	340	850	1460	2265	3520	5300	7400	9280	10500
		300	320	800	1375	2265	3320	5000	6980	8750	9900
20	500	150	430	1100	1940	3200	4800	7000	9900	12390	14000
		300	400	1020	1800	2970	4460	6500	9190	11500	13000
24	600	150	650	1700	2940	4830	7300	10700	14900	18500	21000
		300	605	1580	2730	4485	6780	9940	13840	17180	19500
26	650	150	780	2000	3500	5700	8600	12700	17700	22100	25000
28	700	150	800	2350	4100	6700	10000	14700	20550	25600	29000

### Basic Formulas for Cv-value and Flow Data

#### LIQUIDS

$$Q = \frac{Cv}{1.17} \sqrt{\frac{\Delta P}{G}}$$

#### STEAM

$$\textcircled{1} \Delta P < \frac{P_1}{2}$$

$$W = \frac{135 Cv \sqrt{(\Delta P)(P_1 - P_2)}}{K}$$

#### STEAM IN GENERAL

$$\textcircled{2} \Delta P \geq \frac{P_1}{2}$$

$$Q = \frac{236 Cv P_1}{\sqrt{G(273 + T)}}$$

#### GASES

$$\textcircled{1} \Delta P < \frac{P_1}{2}$$

$$Q = 272 Cv \sqrt{\frac{\Delta P(P_1 + P_2)}{G(273 + T)}}$$

$$\textcircled{2} \Delta P \geq \frac{P_1}{2}$$

$$W = \frac{11.9 Cv P_1}{K}$$

$$\textcircled{2} \Delta P \geq \frac{P_1}{2}$$

$$Q = \frac{236 Cv P_1}{\sqrt{G(273 + T)}}$$

$Q$  : Volume rate of flow(liquid m<sup>3</sup>/h, gas Nm<sup>3</sup>/h)  
 $W$  : Volume rate of flow(steam kg/h)  
 $P_1$  : Intet pressure(liquid kgf/cm<sup>2</sup>, gas/steam kgf/cm<sup>2</sup>, abs.)  
 $P_2$  : Outlet pressure(liquid kgf/cm<sup>2</sup>, gas/steam kgf/cm<sup>2</sup>, abs.)  
 $\Delta P$  : Pressure drop  $P_1 - P_2$ (kgf/cm<sup>2</sup>)  
 $G$  : Specific gravity of fluid(water=1, air=1)  
 $T$  : Temperature of fluid(°C)

$K$  :  $1 + (0.0013 \times TSH)$   
 $TSH$ (°C)=Total temperature minus saturation temperature  
 $V_1$  : Specific volume(cm<sup>3</sup>/g... $P_1$ )  
 $V_2$  : Specific volume(cm<sup>3</sup>/g... $P_2$ )  
*Notes* : When  $P_2 < \frac{1}{2} P_1$ , use  $\frac{P_1}{2}$  instead of  $P_2$   
 For  $V_2$ , use  $V_2$  in accordance with