

TYPE: A3GL1-A150

API 600 GLOBE VALVE - CLASS 150 - A216-WCB

BOLTED BONNET - OUTSIDE SCREW & YOKE - RISING STEM

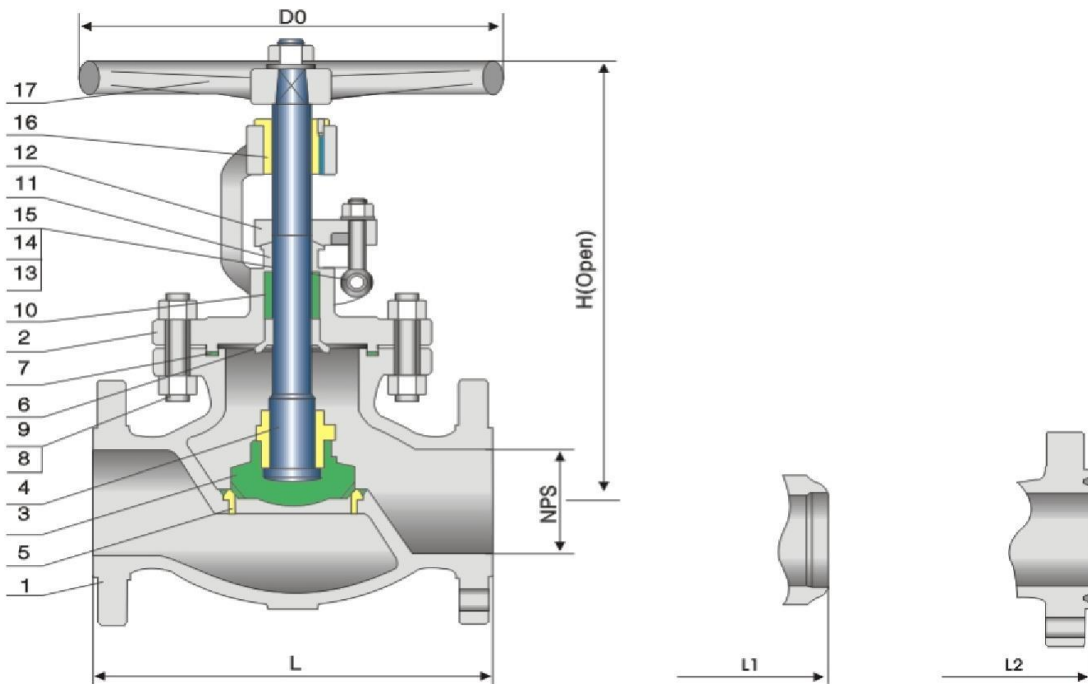

NO.	PART NAME	MATERIAL
1	Body	A216-WCB
2	Bonnet	A216-WCB
3	Disc	WCB+13Cr
4	Stem	A182 F6a
5	Seat ring	A105+13Cr
6	Back seat	A276 410
7A	Bonnet gasket	304+graphite
7B	Ring gasket	Soft steel
8	Bonnet bolt	A193 B7
9	Bonnet nut	A194 2H
10	Packing	Graphite
11	Gland	A276 410
12	Gland Flange	A216-WCB
13	Eyebolt	Carbon steel
14	Eyebolt nut	Carbon steel
15	Eyebolt pin	A276 410
16	Yoke sleeve	Bronze
17	Handwheel	Malleable Iron
18	Wheel nut	Carbon steel

DIMENSIONS:

SIZE	DN	L (RF)	L1 (BW)	L2 (RTJ)	H	DO								
2"	50	203	203	216	380	180								
2.5"	65	216	216	229	390	240								
3"	80	241	241	254	445	280								
4"	100	292	292	305	515	280								
6"	150	406	406	419	560	320								
8"	200	495	495	508	615	320								
10"	250	622	622	635	815	400								
12"	300	698	698	711	910	450								
14"	350	787	787	800	1230	500								
16"	400	914	914	927	1450	600								

MANUFACTURE STANDARD	Valve Design			API 600 BS1873	
	Valve Test			API 598	
	Flange End Dimension			ASME B16.5	
	Face to Face			ASME B16.10	
	Pressure Temperature Rating			ASME B16.34	
Drawing No.	Date	Type	Rev. No.	By	
A31006	2016.05.30	A3GL1-A150	03	AT	
BOLTED BONNET - OUTSIDE SCREW & YOKE - RISING STEM					
TTS VALVE TECHNOLOGIES SDN BHD					