

TYPE: A3GLB-PN16

BELLOWS SEAL GLOBE VALVE (DN15~DN150)

PN16 - GS-C25

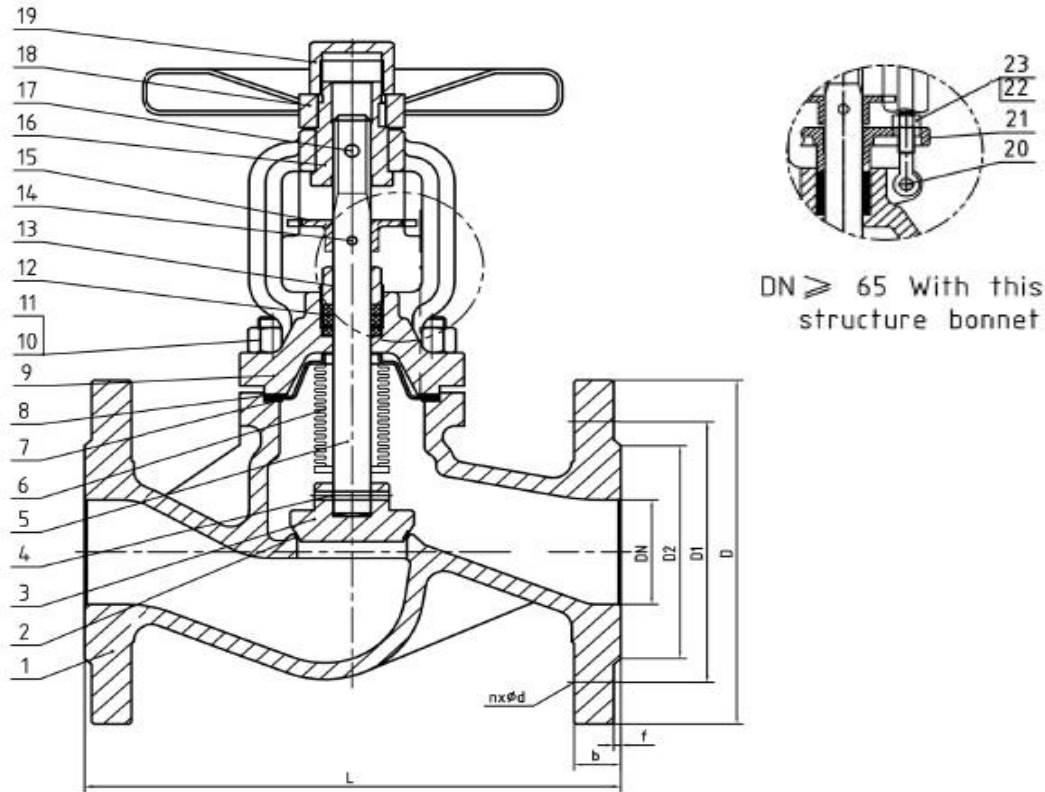

DIMENSIONS:

SIZE	DN	L	D	D1	D2	b	f	n-Ød					
1/2"	15	130	95	65	45	14	2	4-14					
3/4"	20	150	105	75	58	16	2	4-14					
1"	25	160	115	85	68	16	2	4-14					
1-1/4"	32	180	140	100	78	18	2	4-18					
1-1/2"	40	200	150	110	88	18	3	4-18					
2"	50	230	165	125	102	20	3	4-18					
2.5"	65	290	185	145	122	20	3	4-18					
3"	80	310	200	160	138	22	3	8-18					
4"	100	350	220	180	158	22	3	8-18					
5"	125	400	250	210	188	22	3	8-18					
6"	150	480	285	240	212	24	3	8-22					

NO.	PART NAME	MATERIAL
1	Body	GS-C25
2	Seat	GS-C25+Cr13
3	Disc	A105+13Cr
4	Pin	304
5	Stem	13Cr
6	Bellows	304
7	Sealing	304
8	Gasket	Graphite+304
9	Bonnet	GS-C25
10	Bolt	A193-B7
11	Nut	A194-2H
12	Packing	Flexible Graphite
13	Gland	A105
14	Pin	1035
15	Locator	1025
16	Stem Nut	Steel
17	Oil Cup	Copper alloy
18	Handwheel	1025
19	Cap	A105
20	Pin	1035
21	Gland	GS-C25
22	Jack Bolt	A194-2H
23	Nut	A193-B7

MANUFACTURE STANDARD	Valve Design		DIN 3356		
	Test & Inspection		DIN 3230		
	Flange End Dimension		DIN 2543-2545		
	Face to Face		DIN 3202		
	Max. Temperature		350 °C		
Drawing No.	Date	Type	Rev. No.	By	
A31007	2016.05.30	A3GLB-PN16	02	AT	
PN16 - GS-C25					
TTS VALVE TECHNOLOGIES SDN BHD					