

TYPE: A3GLB-PN16

BELLOWS SEAL GLOBE VALVE (DN200~DN400)

PN16 - GS-C25

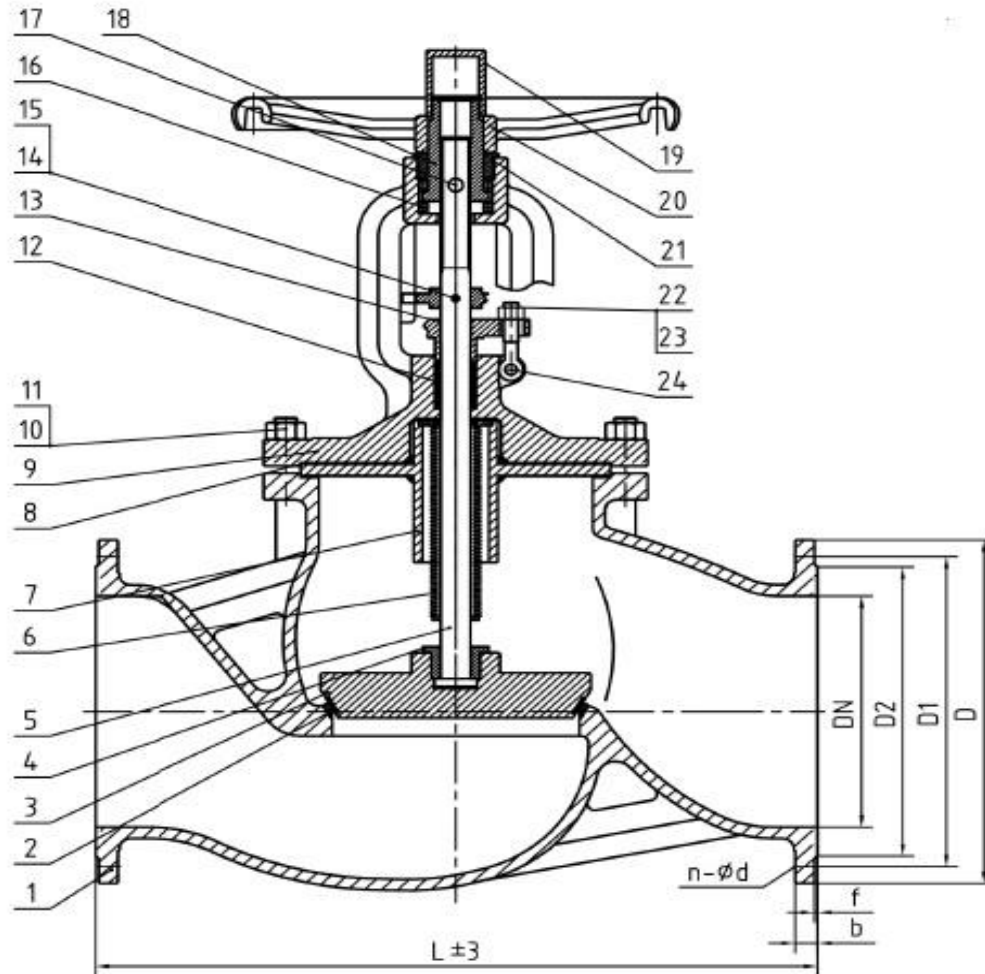

DIMENSIONS:

SIZE	DN	L	D	D1	D2	b	f	n-∅d						
8"	200	600	340	295	268	24	3	12-22						
10"	250	730	405	355	320	26	3	12-26						
12"	300	850	460	410	378	28	4	12-26						
14"	250	980	520	470	438	30	4	16-26						
16"	400	1100	580	525	490	32	4	16-30						

NO.	PART NAME	MATERIAL
1	Body	GS-C25
2	Seat	GS-C25+Cr13
3	Disc	A105+13Cr
4	Disc Cap	A105
5	Stem	13Cr
6	Bellows	304
7	Sealing	1025
8	Gasket	Graphite+304
9	Bonnet	GS-C25
10	Bolt	A193-B7
11	Nut	A194-2H
12	Packing	Graphite
13	Gland	GS-C25
14	Pin	1035
15	Locator	GS-C25
16	Bearing	Steel
17	Oil Cup	Copper alloy
18	Stem Nut	Steel
19	Cap	A105
20	Handwheel	Cast steel
21	Bearing Cap	A105
22	Nut	A194-2H
23	Bolt	A193-B7
24	Pin	1035

MANUFACTURE STANDARD	Valve Design	DIN 3356
	Test & Inspection	DIN 3230
	Flange End Dimension	DIN 2543-2545
	Face to Face	DIN 3202
	Max. Temperature	350 °C

Drawing No.	Date	Type	Rev. No.	By
A31008	2016.05.30	A3GLB-PN16	02	AT
PN16 - GS-C25				
TTS VALVE TECHNOLOGIES SDN BHD				