

TYPE: A3GLB-PN40

BELLOWS SEAL GLOBE VALVE (DN200~DN400)

PN40 - GS-C25

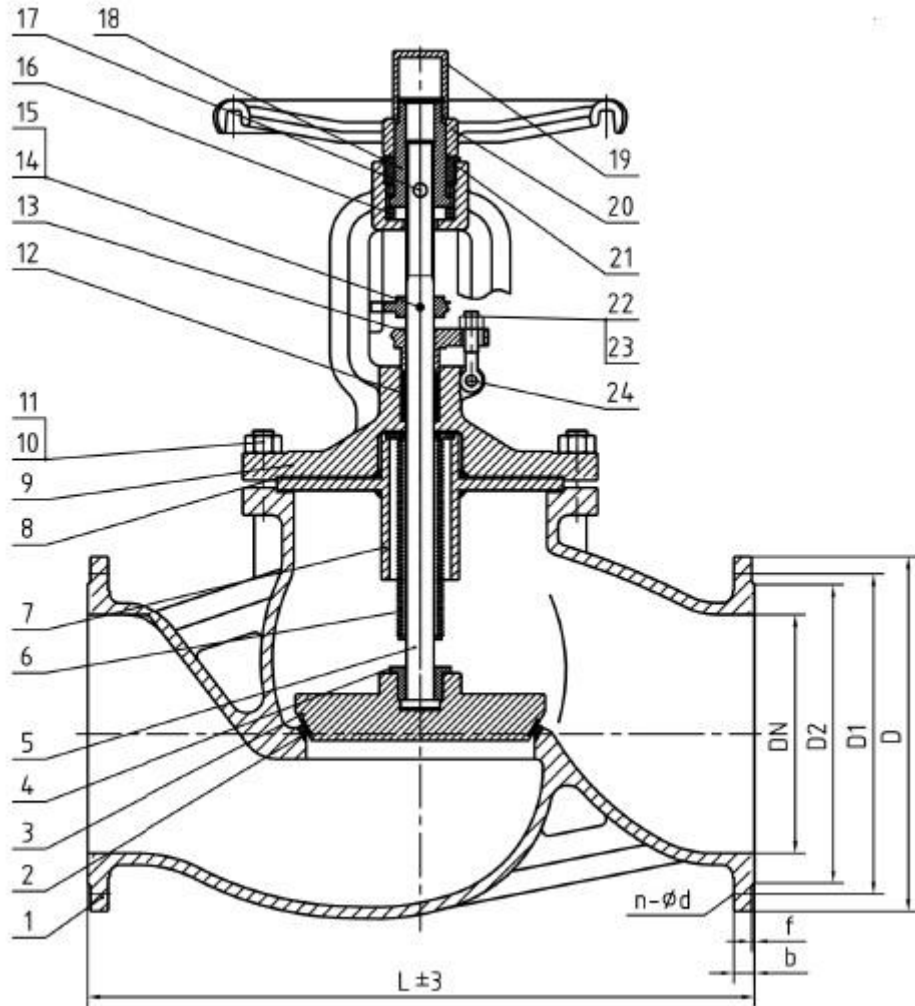

DIMENSIONS:

SIZE	DN	L	D	D1	D2	b	f	n-∅d				Drawing No.	Date	Type	Rev. No.	By
8"	200	600	375	320	285	34	3	12-30				A31010	2016.05.30	A3GLB-PN40	02	AT
10"	250	730	450	385	345	38	3	12-33				PN40 - GS-C25 TTS VALVE TECHNOLOGIES SDN BHD				
12"	300	850	515	450	410	42	3	16-33								
14"	250	980	580	510	465	46	3	16-36								
16"	400	1100	660	585	535	50	3	16-39								

NO.	PART NAME	MATERIAL
1	Body	GS-C25
2	Seat	GS-C25+Cr13
3	Disc	A105+13Cr
4	Disc Cap	A105
5	Stem	13Cr
6	Bellows	304
7	Sealing	1025
8	Gasket	Graphite+304
9	Bonnet	GS-C25
10	Bolt	A193-B7
11	Nut	A194-2H
12	Packing	Graphite
13	Gland	GS-C25
14	Pin	1035
15	Locator	GS-C25
16	Bearing	Steel
17	Oil Cup	Copper alloy
18	Stem Nut	Steel
19	Cap	A105
20	Handwheel	Cast steel
21	Bearing Cap	A105
22	Nut	A194-2H
23	Bolt	A193-B7
24	Pin	1035
MANUFACTURE STANDARD	Valve Design	DIN 3356
	Test & Inspection	DIN 3230
	Flange End Dimension	DIN 2543-2545
	Face to Face	DIN 3202
	Max. Temperature	350 °C