

TYPE: A1GLP-PN16
S-PATTERN GLOBE VALVE
CAST IRON - PN16

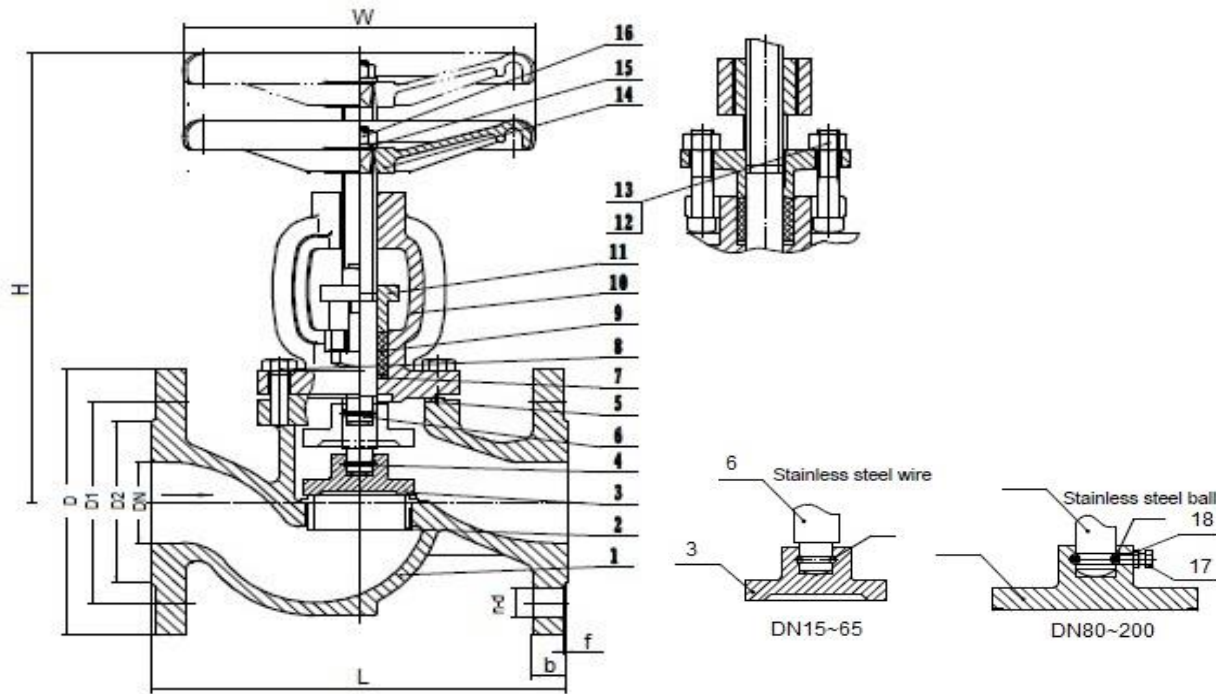

DIMENSIONS:

SIZE	DN	L	D	D1	D2	b	f	n-Ød	H	W
1/2"	15	130	95	65	46	14	2	4-14	167/180	96
3/4"	20	150	105	75	56	16	2	4-14	166/179	96
1"	25	160	115	85	65	16	2	4-14	183/200	120
1.25"	32	180	140	100	76	18	2	4-19	215/231	140
1.5"	40	200	150	110	84	18	2	4-19	220/247	140
2"	50	230	165	125	99	20	2	4-19	239/270	200
2.5"	65	290	185	145	120	20	2	4-19	266/306	200
3"	80	310	200	160	132	22	2	8-19	317/363	240
4"	100	350	220	180	156	24	2	8-19	339/397	280
5"	125	400	250	210	184	26	2	8-19	411/472	360
6"	150	480	285	240	211	26	2	8-23	441/514	360
8"	200	600	340	295	266	30	2	12-23	499/576	400

NO.	PART NAME	MATERIAL
1	Body	GG25
2	Seat	Z2Cr13
3	Disc (DN15-65)	Z2Cr13
3	Disc (DN80-200)	A105+Z2Cr13
4	SS wire/ball	304 stainless steel
5	Gasket	08+flexible graphite
6	Stem	2Cr13
7	Gasket	Q235
8	Bolt	35# steel
9	Packing	Flexible graphite
10	Bonnet	GG25
11	Gland	GG25
12	T-type bolt	35# steel
13	Nut	25# steel
14	Handwheel	QT450-10
15	Gasket	Q235
16	Nut	25# steel
17	Bolt	35# steel
18	Nut	35# steel

MANUFACTURE STANDARD

Valve Design	DIN 3356
Valve Test	EN 12266-1
Flange End Dimension	EN 1092-2
Face to Face	DIN 3202
Max. Temperature	200 °c

Drawing No.	Date	Type	Rev. No.	By
A16001	2016.05.30	A1GLP-PN16	02	AT

CAST IRON - PN16

TTS VALVE TECHNOLOGIES SDN BHD